



CLIENTS | PEOPLE | PERFORMANCE

Haast Courts Block F
BU 0792-006 EQ2
Detailed Engineering Evaluation
Quantitative Report
Version FINAL

151 Stanmore Road, Linwood



**Haast Courts Block F
BU 0792-006 EQ2**

Detailed Engineering Evaluation
Quantitative Report
Version FINAL

151 Stanmore Road, Linwood

Christchurch City Council

Prepared By
Kevan O Brien

Reviewed By
Peter O Brien

Date
31/10/12

Contents

Quantitative Report Summary	i
1. Background	1
2. Compliance	2
2.1 Canterbury Earthquake Recovery Authority (CERA)	2
2.2 Building Act	3
2.3 Christchurch City Council Policy	4
2.4 Building Code	4
3. Earthquake Resistance Standards	5
4. Building Description	7
4.1 General	7
4.2 Gravity Load Resisting System	8
4.3 Lateral Load Resisting System	8
5. Assessment	9
5.1 Qualitative Assessment	9
5.2 Quantitative Assessment	9
6. Damage Assessment	13
6.1 Surrounding Buildings	13
6.2 Residual Displacements and General Observations	13
6.3 Ground Damage	13
7. Geotechnical Investigation	14
7.1 Site Description	14
7.2 Published Information on Ground Conditions	14
7.3 Seismicity	16
7.4 Field Investigations	17
8. Survey	21
9. Initial Capacity Assessment	22
9.1 % NBS Assessment	22
9.2 Seismic Parameters	22
9.3 Wall Bracing Demand	22

9.4	Wall Bracing Capacity	23
9.5	Shear capacity	24
9.6	Out of plane moment capacity	25
9.7	Occupancy	25
10.	Strengthening	26
11.	Recommendations	27
12.	Limitations	28
12.1	General	28
12.2	Geotechnical Limitations	28

Table Index

Table 3.1	%NBS compared to relative risk of failure	6
Table 7.1	EQC Geotechnical Investigation Summary Table	14
Table 7.2	Summary of Known Active Faults	16
Table 7.3	Coordinates of Investigation Locations	17
Table 7.4	Summary of CPT-Inferred Lithology	18
Table 7.5	Summary of Liquefaction Susceptibility	19
Table 9.1	%NBS results from detailed wall bracing calculations	22
Table 9.2	%NBS results from shear and moment capacity calculations	22
Table 9.3	Bracing capacity along the building	23
Table 9.4	Bracing capacity across the building	23
Table 9.5	Shear stress capacities	24

Appendices

- A Photographs
- B Existing Drawings
- C CERA Building Evaluation Form
- D Geotechnical Analysis

Quantitative Report Summary

Haast Courts Block F

BU 0792-006 EQ2

Detailed Engineering Evaluation

Quantitative Report - SUMMARY

Version FINAL

151 Stanmore Road, Linwood

Background

This is a summary of the Quantitative report for the above building structure, and is based in general on NZS 3604:2011 Timber-Framed buildings, NZS 4230: 2004 Design of Reinforced Concrete Masonry Structures as well as a full measure of the building carried out on 10 May 2012.

Brief Description

Haast Courts Block F is a single storey multi residential block building consisting of two residential units. Other Haast Courts blocks are located to the north, east, west and south of the building

The building was constructed in 1979.

The building structure is timber with plasterboard lined walls and is clad with '10 series' concrete block masonry veneer 100mm thickness. The roof is timber framed with concrete tiles and the floors are concrete slab on grade.

The masonry cladding appears to be unfilled or partially unfilled and unreinforced. This is visible in a collapsed gable end of block G. Where the gable has collapsed it is unfilled and unreinforced, this detail may also apply to the other masonry elements of the building. The archived construction drawings also appear to confirm the unreinforced nature of the masonry cladding. Each unit is also separated by a thicker 200mm wall of partially filled reinforced concrete bond beam style masonry construction, which continues above eave level to meet the roof.

Key Damage Observed

- Cracking at concrete block masonry wall

Indicative Building Strength (from IEP and CSW assessment)

Based on the quantitative analysis carried out on the structure NZS 3604:2011 Timber-Framed buildings, NZS 4230: 2004 Design of Reinforced Concrete Masonry Structures and referencing the New Zealand Society for Earthquake Engineering (NZSEE) guidelines, the structure of the building has been assessed to be in the order of 84% NBS along the building and 100% NBS across. Based on this, the

overall %NBS for the building is 84%. However the masonry cladding represents a significant seismic risk and action is recommended as outlined below.

Recommendations

As the building frame has been assessed to have a %NBS greater than 67%NBS, it is not deemed to be an Earthquake Risk and as such no strengthening works to the frame are required. However, the masonry veneer is a seismic risk, in particular the upper section of the gable walls. One of these sections has collapsed and collapses of similar sections are possible under earthquake loads. It is recommended that the upper section of the gable walls are removed and replaced with lightweight cladding.

The following action is recommended:

- ▶ The upper section of the gable walls are either removed or tied back to the building frame immediately as collapses of these sections are possible under earthquake load.
- ▶ The masonry walls are apparently unreinforced and the drawings do not indicate that there are tied back to the wall framing. Localised removal of the linings is recommended to identify if the veneer is tied back.
- ▶ If the veneer is found not to be tied back to the wall framing it is recommended that the veneer is either removed and replaced with light weight cladding or is tied back to the framing with masonry ties.
- ▶ The areas adjacent to the unreinforced gable walls should be cordoned off until the above recommendations have been completed.

1. Background

GHD Limited has been engaged by the Christchurch City Council (CCC) to undertake a detailed engineering evaluation of the Haast Courts Block F.

This report is a Quantitative Assessment and is based in general on NZS 3604: 2011 Timber-Framed buildings and the New Zealand Society for Earthquake Engineering (NZSEE) guidelines.

A quantitative assessment involves a full site measure of the building which is used to determine the buildings bracing capacity in accordance with manufacturers' guidelines where available. When the manufacturers' guidelines are not available, values for material strengths are taken from Table 11.1 of the NZSEE guidelines for the Assessment and Improvement of the Structural Performance of Buildings in Earthquakes. The demand for the building is determined in accordance with NZS 3604: 2011 and the percentage of new building standard (%NBS) is assessed.

At the time of this report, no intrusive site investigation or modelling of the building structure had been carried out. The detailed analysis consisted of a bracing calculation of the structure and a moment and shear capacity check of the fire walls, no further analysis or calculations were carried out.

2. Compliance

This section contains a brief summary of the requirements of the various statutes and authorities that control activities in relation to buildings in Christchurch at present.

2.1 Canterbury Earthquake Recovery Authority (CERA)

CERA was established on 28 March 2011 to take control of the recovery of Christchurch using powers established by the Canterbury Earthquake Recovery Act enacted on 18 April 2011. This act gives the Chief Executive Officer of CERA wide powers in relation to building safety, demolition and repair. Two relevant sections are:

Section 38 – Works

This section outlines a process in which the chief executive can give notice that a building is to be demolished and if the owner does not carry out the demolition, the chief executive can commission the demolition and recover the costs from the owner or by placing a charge on the owners' land.

Section 51 – Requiring Structural Survey

This section enables the chief executive to require a building owner, insurer or mortgagee carry out a full structural survey before the building is re-occupied.

We understand that CERA will require a detailed engineering evaluation to be carried out for all buildings (other than those exempt from the Earthquake Prone Building definition in the Building Act). It is anticipated that CERA will adopt the Detailed Engineering Evaluation Procedure document (draft) issued by the Structural Advisory Group on 19 July 2011. This document sets out a methodology for both qualitative and quantitative assessments.

The qualitative assessment is a desk-top and site inspection assessment. It is based on a thorough visual inspection of the building coupled with a review of available documentation such as drawings and specifications. The quantitative assessment involves analytical calculation of the buildings strength and may require non-destructive or destructive material testing, geotechnical testing and intrusive investigation.

It is anticipated that factors determining the extent of evaluation and strengthening level required will include:

- ▶ The importance level and occupancy of the building
- ▶ The placard status and amount of damage
- ▶ The age and structural type of the building
- ▶ Consideration of any critical structural weaknesses
- ▶ The extent of any earthquake damage

2.2 Building Act

Several sections of the Building Act are relevant when considering structural requirements:

Section 112 – Alterations

This section requires that an existing building complies with the relevant sections of the Building Code to at least the extent that it did prior to any alteration. This effectively means that a building cannot be weakened as a result of an alteration (including partial demolition).

Section 115 – Change of Use

This section requires that the territorial authority (in this case Christchurch City Council (CCC)) be satisfied that the building with a new use complies with the relevant sections of the Building Code 'as near as is reasonably practicable'. Regarding seismic capacity 'as near as reasonably practicable' has previously been interpreted by CCC as achieving a minimum of 67% NBS however where practical achieving 100% NBS is desirable. The New Zealand Society for Earthquake Engineering (NZSEE) recommend a minimum of 67% NBS.

2.2.1 Section 121 – Dangerous Buildings

The definition of dangerous building in the Act was extended by the Canterbury Earthquake (Building Act) Order 2010, and it now defines a building as dangerous if:

- ▶ In the ordinary course of events (excluding the occurrence of an earthquake), the building is likely to cause injury or death or damage to other property; or
- ▶ In the event of fire, injury or death to any persons in the building or on other property is likely because of fire hazard or the occupancy of the building; or
- ▶ There is a risk that the building could collapse or otherwise cause injury or death as a result of earthquake shaking that is less than a 'moderate earthquake' (refer to Section 122 below); or
- ▶ There is a risk that that other property could collapse or otherwise cause injury or death; or
- ▶ A territorial authority has not been able to undertake an inspection to determine whether the building is dangerous.

Section 122 – Earthquake Prone Buildings

This section defines a building as earthquake prone if its ultimate capacity would be exceeded in a 'moderate earthquake' and it would be likely to collapse causing injury or death, or damage to other property. A moderate earthquake is defined by the building regulations as one that would generate ground shaking 33% of the shaking used to design an equivalent new building.

Section 124 – Powers of Territorial Authorities

This section gives the territorial authority the power to require strengthening work within specified timeframes or to close and prevent occupancy to any building defined as dangerous or earthquake prone.

Section 131 – Earthquake Prone Building Policy

This section requires the territorial authority to adopt a specific policy for earthquake prone, dangerous and insanitary buildings.

2.3 Christchurch City Council Policy

Christchurch City Council adopted their Earthquake Prone, Dangerous and Insanitary Building Policy in 2006. This policy was amended immediately following the Darfield Earthquake of the 4th September 2010.

The 2010 amendment includes the following:

- ▶ A process for identifying, categorising and prioritising Earthquake Prone Buildings, commencing on 1 July 2012;
- ▶ A strengthening target level of 67% of a new building for buildings that are Earthquake Prone;
- ▶ A timeframe of 15-30 years for Earthquake Prone Buildings to be strengthened; and,
- ▶ Repair works for buildings damaged by earthquakes will be required to comply with the above.

The council has stated their willingness to consider retrofit proposals on a case by case basis, considering the economic impact of such a retrofit.

We anticipate that any building with a capacity of less than 33% NBS (including consideration of critical structural weaknesses) will need to be strengthened to a target of 67% NBS of new building standard as recommended by the Policy.

If strengthening works are undertaken, a building consent will be required. A requirement of the consent will require upgrade of the building to comply 'as near as is reasonably practicable' with:

- ▶ The accessibility requirements of the Building Code.
- ▶ The fire requirements of the Building Code. This is likely to require a fire report to be submitted with the building consent application.

2.4 Building Code

The building code outlines performance standards for buildings and the Building Act requires that all new buildings comply with this code. Compliance Documents published by The Department of Building and Housing can be used to demonstrate compliance with the Building Code.

After the February Earthquake, on 19 May 2011, Compliance Document B1: Structure was amended to include increased seismic design requirements for Canterbury as follows:

- ▶ Hazard Factor increased from 0.22 to 0.3 (36% increase in the basic seismic design load)
- ▶ Serviceability Return Period Factor increased from 0.25 to 0.33 (80% increase in the serviceability design loads when combined with the Hazard Factor increase)

The increase in the above factors has resulted in a reduction in the level of compliance of an existing building relative to a new building despite the capacity of the existing building not changing.

3. Earthquake Resistance Standards

For this assessment, the building’s earthquake resistance is compared with the current New Zealand Building Code requirements for a new building constructed on the site. This is expressed as a percentage of new building standard (%NBS). The new building standard load requirements have been determined in accordance with the current earthquake loading standard (NZS 1170.5:2004 Structural design actions - Earthquake actions - New Zealand).

The likely capacity of this building has been derived in accordance with the New Zealand Society for Earthquake Engineering (NZSEE) guidelines ‘Assessment and Improvement of the Structural Performance of Buildings in Earthquakes’ (AISPBE), 2006. These guidelines provide an Initial Evaluation Procedure that assesses a buildings capacity based on a comparison of loading codes from when the building was designed and currently. It is a quick high-level procedure that can be used when undertaking a Qualitative analysis of a building. The guidelines also provide guidance on calculating a modified Ultimate Limit State capacity of the building which is much more accurate and can be used when undertaking a Quantitative analysis.

The New Zealand Society for Earthquake Engineering has proposed a way for classifying earthquake risk for existing buildings in terms of %NBS and this is shown in Figure 1 below.

Description	Grade	Risk	%NBS	Existing Building Structural Performance	Improvement of Structural Performance	
					Legal Requirement	NZSEE Recommendation
Low Risk Building	A or B	Low	Above 67	Acceptable (improvement may be desirable)	The Building Act sets no required level of structural improvement (unless change in use) This is for each TA to decide. Improvement is not limited to 34%NBS.	100%NBS desirable. Improvement should achieve at least 67%NBS
Moderate Risk Building	B or C	Moderate	34 to 66	Acceptable legally. Improvement recommended		Not recommended. Acceptable only in exceptional circumstances
High Risk Building	D or E	High	33 or lower	Unacceptable (Improvement)	Unacceptable	Unacceptable

Figure 1 NZSEE Risk Classifications Extracted from table 2.2 of the NZSEE 2006 AISPBE

Table 1 compares the percentage NBS to the relative risk of the building failing in a seismic event with a 10% risk of exceedance in 50 years (i.e. 0.2% in the next year). It is noted that the current seismic risk in Christchurch results in a 6% risk of exceedance in the next year.

Percentage of New Building Standard (%NBS)	Relative Risk (Approximate)
>100	<1 time
80-100	1-2 times
67-80	2-5 times
33-67	5-10 times
20-33	10-25 times
<20	>25 times

Table 1 %NBS compared to relative risk of failure

4. Building Description

4.1 General

Haast Courts Block F is located at 151 Stanmore Road within the suburb of Linwood approximately 2km east of Christchurch CBD.

The site is predominantly flat and surrounded by residential properties and bordered to the east by Stanmore Road and to the south by Haast Street.

Haast Courts Block F is a single storey multi residential block building consisting of two residential units. Other Haast Courts blocks are located to the north, east, west and south of the building

The building was constructed in 1979.

The building structure is timber with plasterboard lined walls and is clad with '10 series' concrete block masonry veneer 100mm thickness. The roof is timber framed with concrete tiles and the floors are concrete slab on grade.

The masonry cladding appears to be unfilled or partially unfilled and unreinforced. This is visible in a collapsed gable end of block G. Where the gable has collapsed it is unfilled and unreinforced, this detail may also apply to the other masonry elements of the building. The archived construction drawings also appear to confirm the unreinforced nature of the masonry cladding. Each unit is also separated by a thicker 200mm wall of partially filled reinforced concrete bond beam style masonry construction, which continues above eave level to meet the roof.

The dimensions of the building are approximately 13.8m long, 6.8m wide and 4.7m in height. The overall footprint of the building is approximately 94m². Sketch of key details are shown in Figure 2.

Planning drawings were made available for this building.

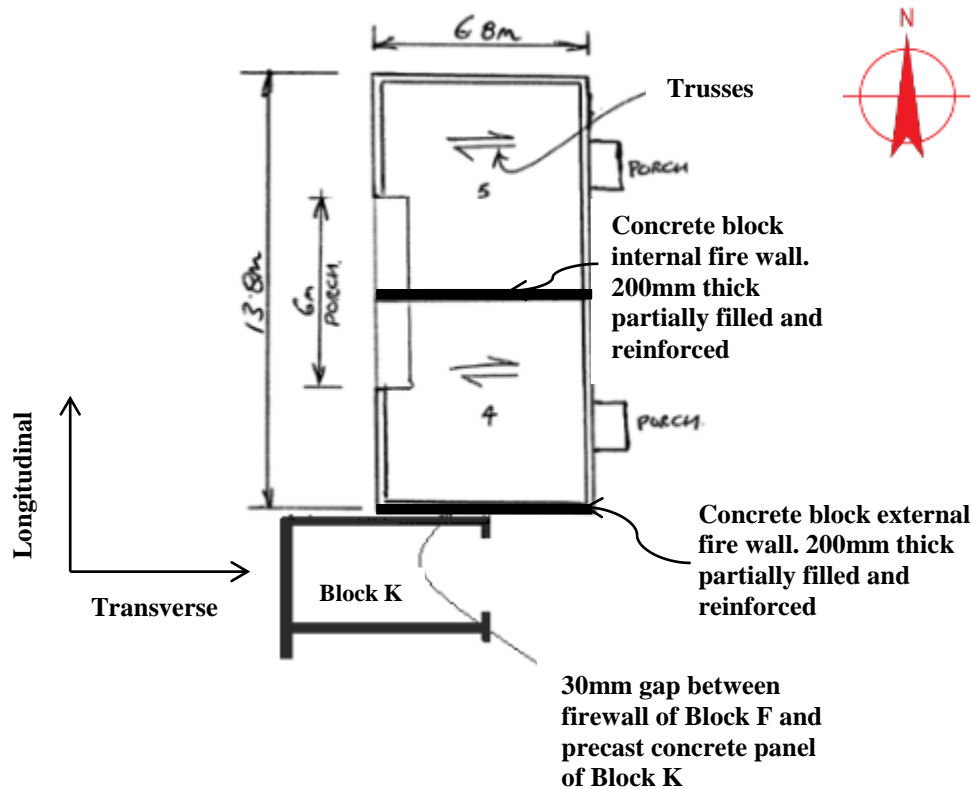

Figure 2 Plan sketch show key structural elements

4.2 Gravity Load Resisting System

Self-weight and applied roof loads are carried by timber roof trusses which span the building in the transverse direction. Load from the trusses is transferred to the supporting timber framed external walls and these bear on concrete strip foundations which allow the total building load above including the masonry cladding to be supported by the ground beneath. The floor is a concrete slab which supports all floor loads and was poured directly onto compacted soils and strip foundations which support its edges.

4.3 Lateral Load Resisting System

Seismic loads in both lateral directions are resisted primarily by the plasterboard lined timber framed walls performing as in-plane bracing panels. The external walls are also likely to have steel diagonal bracing straps or angles present as these are shown on the elevations of the archived construction drawings.

In addition to this timber framed wall bracing, the reinforced fire wall masonry will also provide resistance to seismic demand in the transverse direction.

The heavy masonry wall and masonry veneer cladding materials of this building makes the presence of a ceiling diaphragm very important to prop the out-of-plane seismic load of these items. Though no diagonal ceiling bracing could be observed, a plasterboard ceiling was present and is likely to provide some nominal diaphragm capability.

5. Assessment

5.1 Qualitative Assessment

An initial qualitative assessment has been completed by GHD for the building. This included a visual inspection of the building which was undertaken on 8th of March 2012. Both the interior and exterior of the building were inspected. The main structural elements of the building were the timber framed roof with heavy tile cladding and the plasterboard lined timber framed walls with brick veneer. A 200mm thick filled reinforced masonry fire wall separated the individual units. No diagonal bracing was visible in the roof.

The visual inspection consisted of observing the building to determine the structural systems and likely behaviour of the building during an earthquake. The site was assessed for damage, including observing the ground conditions, checking for damage in areas where damage would be expected for the structure type observed and noting general damage observed throughout the building in both structural and non-structural elements. A review of available drawings was also carried out.

Based on the information available, and using the NZSEE Initial Evaluation Procedure, the buildings original capacity has been assessed to be in the order of 45% NBS and post-earthquake capacity in the order of 45% NBS. The buildings post-earthquake capacity excluding critical structural weakness is in the order of 65% NBS.

5.2 Quantitative Assessment

The buildings bracing capacity was calculated in accordance with NZS 3604:2011 and the NZSEE guidelines. The demand for the building was calculated in accordance with NZS 3604: 2011 and the percentage of new building standard (%NBS) was assessed.

5.2.1 Building demand

The demand on the structure was determined in accordance with Section 5 of NZS 3604: 2011. The bracing unit demand per square metre was determined from Table 5.10. The building is located in Christchurch (zone 2) on class D soils. Therefore a multiplication factor of 0.8 is applied in accordance with Table 5.10 of NZS 3604: 2011.

An Importance Level of 2 was used for the calculations. This results in the Return Period Factor, as given by Table 3.5 of NZS 1170.5: 2004 and as prescribed by Table 3.3 of NZS 1170.1: 2004, for the building as 1.0 and therefore no increase or decrease to the demand is necessary.

5.2.2 Wall bracing capacity

The building was constructed in 1979 and as such, no bracing capacities for the wall linings were available for the calculations. Therefore the capacities are taken in accordance with Table 11.1 of the in NZSEE guidelines Table 11.1.

Section 11.4 of the NZSEE guidelines states that shear panels can utilise their full bracing capacity for aspect ratios (height-to-width) up to 2:1. For aspect ratios greater than 2:1 and up to 3.5:1 a limiting factor can be applied in accordance with the NEHRP Recommended Provisions (BSSC, 2000) as follows;

$$\text{Aspect ratio factor} = \frac{2 \times \text{Width}}{\text{Height}}$$

Any sections of wall with an aspect ratio greater than 3.5:1 were not included for the purpose of the bracing calculations.

5.2.3 Ceiling diaphragm

The fixing details of the ceilings could not be determined. Therefore where the ceiling dimensions exceed that specified in NZS 3640: 2011, the capacity is determined by;

$$\%NBS = \frac{\text{Permitted length}}{\text{Actual length}} \times 100\%$$

Where the permitted length is the maximum dimension for a standard plasterboard lined ceiling (e.g. 7.5m)

5.2.4 Overturning

The overturning of the reinforced masonry walls was checked to investigate whether the walls were adequately secured from overturning against their design bracing capacity. As the eccentricity of the resultant load fell outside the wall line the walls bracing capacity was discounted towards calculating the %NBS.

5.2.5 Seismic weight coefficient

The elastic site hazard spectrum for horizontal loading, $C(T)$, for the building was derived from Equation 3.1(1);

$$C(T) = C_h Z R N(T, D)$$

Where

$C_h(T)$ = the spectral shape factor determined from CL 3.1.2

Z = the hazard factor from CL 3.1.4 and the subsequent amendments which increased the hazard factor to 0.3 for Christchurch

R = the return period factor from Table 3.5 for an annual probability of exceedance of 1/500 for an Importance Level 2 building

$N(T, D)$ = the near-fault scaling factor from CL 3.1.6

The structural performance factor, S_p , was calculated in accordance with CL 4.4.2

$$S_p = 1.33 - 0.3\mu$$

Where μ , the structural ductility factor, was taken as 1.25.

The seismic weight coefficient was then calculated in accordance with CI 5.2.1.1 of NZS 1170.5: 2011. For the purposes of calculating the seismic weight coefficient a period, T_1 , of 0.4 was assumed for the building. The coefficient was then calculated using Equation 5.2(1);

$$C_d(T_1) = \frac{C(T_1)S_p}{k_\mu}$$

Where

$$k_{\mu} = \frac{(\mu - 1)T_1}{0.7} + 1$$

5.2.6 Shear capacity

The shear capacity of the reinforced filled masonry wall was determined using NZS 4230: 2004. As there are no details as to the level of supervision during the construction stage, the Observation Type was classed accordance with Table 3.1. The strength reduction factor, ϕ , for shear and shear friction was taken as 0.75 in accordance with Cl 3.4.7. The overall shear capacity of the wall was calculated from Cl 10.3.2.1, Equation 10-4;

$$V_n = v_n b_w d \phi$$

Where

v_n = the total shear stress which consists of the contribution of the masonry, v_m , the axial load, v_p and the contribution of the shear reinforcement, v_s .

b_w = the thickness of the wall

d = 0.8 times the length of the wall

5.2.7 Moment capacity

The moment capacity of the reinforced filled masonry wall was determined using NZS 4230: 2004 and the user's guide to NZS 4230: 2004. The strength reduction factor, ϕ , for flexure with or without axial tension or compression was taken as 0.85 in accordance with Cl 3.4.7. The overall shear capacity of the wall was calculated using the formula;

$$M_n = (N_n + A_s f_y) x \left(\frac{t - a}{2} \right) x \phi$$

Where

$$a = \frac{N_n + A_s f_y}{0.85 f'_m 1.0}$$

N_n = the axial load due to the self weight of the wall

A_s = the area of steel reinforcement

f_y = the strength of steel as specified by the NZSEE guidelines

f'_m = specified compressive strength of masonry from Table 10.1

t = thickness of the masonry wall

5.2.8 %NBS

The bracing capacity both along and across the building, the shear capacity of the wall and the out of plane moment capacity were then compared to their respective demands to assess which was the most critical and thus determine the overall %NBS for the building

$$\%NBS = \frac{BU_{provided}}{BU_{demand}} \times \%100$$

$$\%NBS = \frac{V_n}{V^*} \times \%100$$

$$\%NBS = \frac{M_n}{M^*} \times \%100$$

6. Damage Assessment

6.1 Surrounding Buildings

Hornby Courts Block F is located in a residential complex with 7 other residential blocks and 3 blocks of garages. Some of the older masonry clad residential units have suffered damage with the collapse of a portion of the gable end of Block G being the most noticeable. The only damage noted to the garage blocks is minor cracking to the floor slabs.

6.2 Residual Displacements and General Observations

- Minor cracking was noted throughout the building
- No damage was noted to the roof structure
- No damage was noted to the floor slabs
- Cracking at concrete block masonry wall

6.3 Ground Damage

There was no evidence of ground damage on the property or surrounding neighbours land.

7. Geotechnical Investigation

7.1 Site Description

The site is located in the suburb of Linwood, in eastern Christchurch. It is relatively flat, with an elevation in the order of 5m above mean sea level. The site is approximately 250m south of the Avon River, and 6km west of the coast (Pegasus Bay).

7.2 Published Information on Ground Conditions

7.2.1 Published Geology

The geological map of the area¹ indicates that the site is underlain by:

- ▶ Holocene alluvial soils of the Yaldhurst Member, sub-group of the Springston Formation, comprising alluvial sand and silt overbank deposits.

Figure 72 (Brown & Weeber) indicates that groundwater levels are likely to be within 1m of the surface.

7.2.2 Environment Canterbury Logs

Information from Environment Canterbury (ECan) indicates that one borehole with a lithographic log (Ref. M35/2119) is located 150m north of the site. This indicates that the area is silt/clay to 1.8m bgl, overlying gravels to ~10m bgl, which is shown to be underlain by alternating layers of sand/clay, and gravels.

It should be noted that the boreholes were sunk for groundwater extraction and not for geotechnical purposes. Therefore, the amount of material recovered and available for interpretation and recording will have been variable at best and may not be representative. The logs have been written by the well driller and not a geotechnical professional or to a standard. In addition strength data is not recorded.

7.2.3 EQC Geotechnical Investigations

The Earthquake Commission has undertaken geotechnical testing in the area of the site. Information pertaining to this investigation is included in the Tonkin & Taylor Report for Linwood². Three investigation points were considered, as summarised below in Table 7.1.

Table 7.1 EQC Geotechnical Investigation Summary Table

Bore Name	Grid Reference	Depth (m bgl)	Log Summary
CPT – LWD - 02	2481936.2 mE	0 – 4.5	Soft Silts and Clays
	5742258.3 mN	4.5 – 24.5	Dense Sand

¹ Brown, L. J. & Weeber, J.H. (1992): *Geology of the Christchurch Urban Area*. Institute of Geological and Nuclear Sciences 1:25,000 Geological Map 1. IGNS Limited: Lower Hutt.

² Tonkin & Taylor Ltd (2011): Christchurch Earthquake Recovery, *Geotechnical Factual Report, Linwood*

Bore Name	Grid Reference	Depth (m bgl)	Log Summary
CPT – LWD - 03	2482276.3 mE	0 – 2.0	Loose Sands
	5472317.3 mN	2.0 – 2.5	Soft Silt and Clay
		2.5 – 4.0	Dense Sand
CPT – LWD - 17	2481825.2 mE	0 – 5.0	Silts and Clays
	5472012.7 mN	5.0 – 26.0	Sand

Initial observations of the CPT results indicate the soils are composed predominantly of soft silt and clay underlain by dense sands. This would infer that liquefaction is possible in a significant seismic event.

7.2.4 Land Zoning

Canterbury Earthquake Recovery Authority (CERA) indicates the site is within the Green Zone, meaning repair and rebuild may take place.

CERA has published areas showing the Green Zone Technical Category in relation to the risk of future liquefaction and how these areas are expected to perform in future earthquakes.

Categorised residential properties adjacent to the site are indicated to be TC2 (yellow). This means that minor to moderate land damage from liquefaction is expected in future significant earthquakes.

7.2.5 Post February Aerial Photography

Aerial photography taken following the 22 February 2011 earthquake shows no signs of liquefaction outside the building footprints or adjacent to the site, as shown in Figure 7.1.



Figure 7.1 Post February 2011 Earthquake Aerial Photography³

7.3 Seismicity

7.3.1 Nearby Faults

There are many faults in the Christchurch region, however only those considered most likely to have an adverse effect on the site are detailed below.

Table 7.2 Summary of Known Active Faults^{4,5}

Known Active Fault	Distance from Site	Direction from Site	Max Magnitude	Likely Avg Interval	Recurrence
Alpine Fault	120 km	NW	~8.3	~300 years	
Greendale (2010) Fault	23 km	W	7.1	~15,000 years	
Hope Fault	110 km	N	7.2~7.5	120~200 years	
Kelly Fault	110km	NW	7.2	150 years	
Porters Pass Fault	63 km	NW	7.0	1100 years	

³ Aerial Photography Supplied by Koordinates sourced from <http://koordinates.com/layer/3185-christchurch-post-earthquake-aerial-photos-24-feb-2011/>

⁴ Stirling, M.W, McVerry, G.H, and Berryman K.R. (2002) A New Seismic Hazard Model for New Zealand, Bulletin of the Seismological Society of America, Vol. 92 No. 5, pp 1878-1903, June 2002.

⁵ GNS Active Faults Database

Recent earthquakes since 22 February 2011 have identified the presence of a new active fault system /zone underneath Christchurch City and the Port Hills. Research and published information on this system is in development and not generally available. Average recurrence intervals are yet to be estimated.

7.3.2 Ground Shaking Hazard

This seismic activity has produced earthquakes of Magnitude 6.3 with peak ground accelerations (PGA) up to twice the acceleration due to gravity (2g) in some parts of the city. This has resulted in widespread liquefaction throughout Christchurch.

New Zealand Standard NZS 1170.5:2004 quantifies the Seismic Hazard factor for Christchurch as 0.30, being in a moderate to high earthquake zone. This value has been provisionally upgraded recently (from 0.22) to reflect the seismicity hazard observed in the earthquakes since 4 September 2010.

7.4 Field Investigations

In order to further understand the ground conditions at the site, intrusive testing comprising two piezocone CPT investigations were conducted at the site on 28 June 2012. The locations of the tests are indicated on Figure 7.2 below.

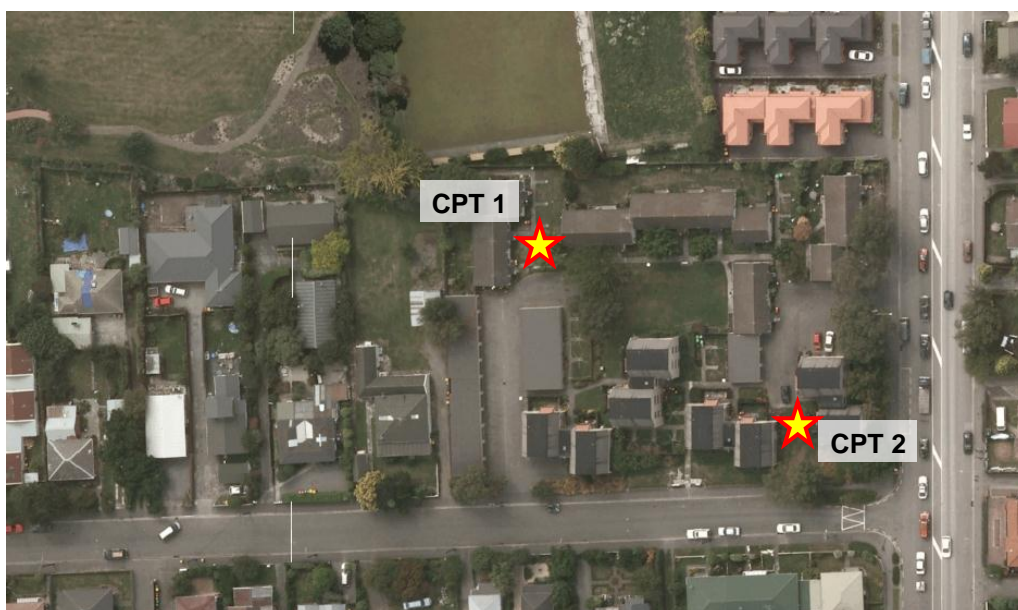

Figure 7.1 Aerial Photograph depicting CPT Investigation Locations³

The coordinates of the test locations are tabulated in Table 7.3.

Investigation	Depth (m bgl)	Easting (NZMG)	Northing (NZMG)
CPT 1	23.07	2482216	5742185
CPT 2	27.89	2482259	5742157

Table 7.3 Coordinates of Investigation Locations

The CPT investigations were undertaken by McMillans Drilling Ltd on 28 June 2012, typically to a target depth of 20m below ground level. However, testing was continued to depths of 23m bgl and 27.9m bgl due to the presence of soft silts and loose sands at 20m. Please refer to Appendix D for CPT logs.

7.4.1 Ground Conditions Encountered

Interpretation of output graphs⁶ from the investigation showing Cone Tip Resistance (q_c), Friction Ratio (Fr), Inferred Lithology and Inferred Liquefaction Potential are summarised in Table 7.4 and Table 7.5.

A summary of the lithology inferred from the CPT results is outlined in Table 7.4 below.

Depth (m)	Inferred Lithology	Cone Tip Resistance q_c (MPa)	Friction Ratio Fr (%)	Relative Density Dr (%)
0 – 6.5	SILT mixtures (with sand lenses)	1 to 8	1 to 6	($S_u \geq 30\text{kPa}$)
6.5 – 10	SANDS	14 to 25	0.5	80 to 100
10 – 16	SANDS	2 to 18	0.5 to 2	50 to 80
16 – 19	SANDS	12 to 30	0.5	70 to 90
19 – 27	Layers of: <ul style="list-style-type: none"> • SILT mixtures; and, • SANDS 	1 15 to 30	~3 0.5	($S_u \geq 50\text{kPa}$) 60 to 80

Table 7.4 Summary of CPT-Inferred Lithology

From the results above, the ground conditions at the site are understood to be predominantly silts to 6.5m, overlying sands to 19m, and layers of sands and silts to depth.

This is considered consistent with the published geology and EQC investigations for the area, from the desktop information reviewed in Sections 7.1.1 and 7.1.3.

Please refer to Appendix D for further detail.

During the CPT investigations, groundwater was inferred to be at 1.2m below ground level. This is slightly lower than, but still consistent with, the inference by Brown & Weeber of groundwater being within 1m of the surface. It is also consistent with site levels in relation to the Avon River.

7.4.2 Liquefaction Analysis

As the subsoils encountered consisted of sand and silt beneath the site, a more comprehensive liquefaction assessment has been undertaken.

⁶ McMillans Drilling CPT data plots, Appendix D.

7.4.2.1 Parameters used in Analysis

Assumptions made for the analysis process are as follows:

- D₅₀ particle sizes for the site soil (sands) from CPT soil analysis;
- Importance Level 2, post seismic event (50-year design life); and,
- Peak ground acceleration (PGA) 0.35g.

The following equation has been used to approximate soil unit weight from the CPT investigation data:⁷

$$\gamma = \frac{\gamma_w G_s}{2.65} \left(0.27 \log Fr + 0.36 \log \left(\frac{q_c}{p_{atm}} \right) + 1.236 \right)$$

This typically gave values ranging between 16 and 20 kN/m³ (saturated).

The liquefaction analysis process has been conducted using the methodology from Robertson & Wride⁸, and from the NZGS Guidelines⁹.

7.4.2.2 Results of Liquefaction Analysis

The results of the liquefaction analysis, as outlined in Table 7.5, indicate that depths to 6.5m, and 10m to 19m, are considered highly liquefiable.

Depth (m)	Inferred Lithology	Triggering Factor F _L	Liquefaction Susceptibility ¹⁰
0 – 6.5	SILT mixtures (with sand lenses)	0.3 to 0.8	High (Bands)
6.5 – 10	SANDS	>> 1	Negligible
10 – 16	SANDS	0.4 to 2	Severe
16 – 19	SANDS	0.3 to 1	High (Bands)
19 – 27	Layers of: <ul style="list-style-type: none"> • SILT mixtures; and, • SANDS. 	- 0.5 to 1.8	<i>Not Liquefiable</i> High

Table 7.5 Summary of Liquefaction Susceptibility

(Bands) means that only some bands of soil are indicated to be susceptible within this layer.

While layers at 19m to 27m are indicated to be highly susceptible by the analysis, the severity of liquefaction at this depth is considered significantly reduced due to the greater levels of vertical overburden stress.

⁷ Robertson P.K., & Cabal K.L. (2010): *Estimating soil unit weight from CPT*. Gregg Drilling & Testing Inc.: Signal Hill, California, USA.

⁸ Robertson P.K. & Wride C.E. (1998): *Evaluating cyclic liquefaction potential using the cone penetration test*. Canadian Geotechnical Journal, 35: pp. 442–459.

⁹ Cubrinovski M., McManus K.J., Pender M.J., McVerry G., Sinclair T., Matuschka T., Simpson K., Clayton P., Jury R. (2010): *Geotechnical earthquake engineering practice: Module 1 – Guideline for the identification, assessment and mitigation of liquefaction hazards*. NZ Geotechnical Society

¹⁰ Table 6.1, NZGS Guidelines Module 1 (2010)

Settlement estimates for the CPT points are between 150mm and 270mm for ULS conditions.

Please refer to Appendix D for further details.

7.4.3 Interpretation of Ground Conditions

7.4.3.1 Liquefaction Assessment

Overall, the site is considered to be highly susceptible to liquefaction. This is based on:

- Limited evidence of liquefaction at the surface in the post-earthquake aerial photography;
- Estimated settlements from the CPT results (150mm to 270mm) are well in excess of the 100mm limit for TC2 classification, indicating the site should be considered in line with TC3 guidelines; and,
- The layers of 1m to 6m and 9m to 17m are indicated to be highly susceptible, as outlined in Table 7.5.

7.4.3.2 Slope Failure and/or Rockfall Potential

The site is located within Linwood, a flat suburb in eastern Christchurch. Global slope instability is considered negligible. However, any localised retaining structures and/or embankments should be further investigated to determine the site-specific slope instability potential.

7.4.3.3 Foundation Recommendations

Based on the information presented above, we recommend the following for the subject site:

- The soil class of **D** (in accordance with NZS 1170.5:2004) recommended in Section 8 of the Qualitative DEE/IEP is still believed to be appropriate; and,
- Any remedial works to foundations (or proposed new structures) be undertaken in accordance with DBH's guidelines for **TC3** land, due to the high levels of estimated settlement.

8. Survey

A level survey will not be required as there is no evidence of significant liquefaction or ground settlement.

9. Initial Capacity Assessment

9.1 % NBS Assessment

Following detailed calculations being carried out, the buildings %NBS from the bracing calculations have been assessed across and along the building and are in the order of that shown below in Table 9.1. The %NBS from the shear and moment capacity checks are below in Table 9.2.

Direction	%NBS
Across	84
Along	100

Table 9.1 %NBS results from detailed wall bracing calculations

	%NBS
Shear capacity	100
Moment capacity	100

Table 9.2 %NBS results from shear and moment capacity calculations

Following a detailed assessment the building has been assessed as achieving 84% New Building Standard (NBS). Under the New Zealand Society for Earthquake Engineering (NZSEE) guidelines the building is not considered potentially an Earthquake Risk building as it achieves above 67% NBS.

9.2 Seismic Parameters

The seismic design parameters based on current design requirements from NZS1170:2002 and the NZBC clause B1 for this building are:

- Site soil class: D, NZS 1170.5:2004, Clause 3.1.3, Soft Soil
- Return period factor $R_u = 1.0$, NZS 1170.5:2004, Table 3.5, Importance Level 2 structure with a 50 year design life.

9.3 Wall Bracing Demand

In accordance with Table 5.10 of NZS 3604: 2011, for a heavy roof, heavy cladding with a pitch between 25°-45° then a bracing demand of 15 BU/m² is taken.

In accordance with Table 5.10 for Earthquake Zone 2 which covers Christchurch and for soil class D, both of these bracing demands are reduced by a factor of 0.8 and so the total building demand for the building is;

$$\begin{aligned}BU_{\text{demand}} &= (0.8 \times 15 \text{ BU/m}^2 \times \text{Floor area}) \\ &= 1092 \text{ BU}\end{aligned}$$

9.4 Wall Bracing Capacity

The bracing capacity of the building was assessed using strengths from the NZSEE guidelines (Table 11.1). Table 11.1 applies a reduction factor of 30% on the bracing capacity due to unknown fixing details of walls constructed prior to 1990. The results of the bracing capacity analysis can be seen in Table 9.3 and Table 9.4.

Section 11.4 of the NZSEE guidelines states that shear panels can utilise their full bracing capacity for aspect ratios (height-to-width) up to 2:1. For aspect ratios greater than 2:1 and up to 3.5:1 a limiting factor is to be applied in accordance with NEHRP Recommended Provisions (BSSC, 2000) as follows;

$$\text{Aspect ratio factor} = \frac{2 \times \text{Width}}{\text{Height}}$$

Any sections of wall with an aspect ratio greater than 3.5:1 were not included for the purpose of the bracing calculations.

Bracing Line	Bracing Capacity (BU)
1	235
2	1184
3	1215
4	149
Total bracing capacity = 2783 BU	

Table 9.3 Bracing capacity along the building

Bracing Line	Bracing Capacity (BU)
1	286
2	386
3	194
4	386
5	Discounted
6	386
7	Discounted
8	386
9	194

10	386
11	Discounted
12	386
13	286
Total bracing capacity = 3276 BU	

Table 9.4 Bracing capacity across the building

9.5 Shear capacity

The total shear stress capacity is given in Table 9.5. A yield stress of 275 MPa was adopted for the reinforcement in accordance with section 7.1.1 of the NZSEE guidelines. An Observation Class of B was assumed for the wall.

NZS 4230: 2004 Clause number	Bracing Line	Bracing Capacity (BU)
10.3.2.6	v_m	1.000
10.3.2.7	v_p	0.082
10.3.2.11	v_s	0.207
$V_n = v_m + v_p + v_s =$		1.289 MPa

Table 9.5 Shear stress capacities

The total shear capacity, V_n , was then calculated in accordance with CI 10.3.2.1. The shear and shear friction reduction factor, ϕ , was then applied to the capacity as follows,

$$\begin{aligned}
 \phi V_n &= v_n b_w d \phi \\
 &= (1.289) \times (200 \times 0.8 \times 6600) \times (0.75) / 1000 \\
 &= 1020 \text{ kN}
 \end{aligned}$$

The shear capacity of the 3.2m length of wall is approximately half that of the 6.6m wall analysed. Taking 40% of the capacity of the 6.6m length of wall the capacity of the 3.2m length of wall at 408 kN is still much greater than the calculated demand of 62.7 kN.

9.6 Out of plane moment capacity

The moment capacity of the 6.6m length reinforced masonry fire wall between units was calculated using the following equation;

$$\begin{aligned}\phi M_n &= (N_n + A_s f_y) \times \left(\frac{t-a}{2}\right) \times \phi \\ &= 4\text{kNm}\end{aligned}$$

The wall was assumed to have a pin-pin connection at the top and bottom of the wall. The maximum moment of the wall was calculated to be 2.4kNm.

9.7 Occupancy

As the building has been assessed to have a %NBS greater than 67%NBS, it is not deemed to be an Earthquake Risk and as such no strengthening works are required. Remedial works are required on the unreinforced block veneer sections and the areas adjacent to the unreinforced gable walls should be cordoned off until the recommendations have been completed. However, there are no immediate collapse hazards associated with the structure therefore general occupancy of the building is permitted.

10. Strengthening

As the %NBS along the building has been assessed at 84%, additional works are not required to the frame of the building. The block veneer sections of wall on the gable end of each individual unit are susceptible to collapse as demonstrated during the recent seismic activity.

The following recommendations are made:

- ▶ The gable sections of masonry veneer are immediately made safe by either removal or tying these to the structure framing
- ▶ The nature of the connection between the masonry veneer and the framing is identified
- ▶ If no positive connection between the masonry veneer is identified then the veneer walls are removed and replaced with lightweight materials or some form of positive connection between the veneer and the framing is added.
- ▶ The areas adjacent to the unreinforced gable walls should be cordoned off until the above recommendations have been completed.

11. Recommendations

As the building has been assessed to have a %NBS greater than 67%NBS, it is not deemed to be an Earthquake Risk and as such no strengthening works are required.

The block veneer sections of wall on the gable end of each individual unit are susceptible to collapse as demonstrated during the recent seismic activity.

The following recommendations are made:

- ▶ The upper section of the gable walls are either removed or tied back to the building frame immediately as collapses of these sections are possible under earthquake load.
- ▶ The masonry walls are apparently unreinforced and the drawings do not indicate that there are tied back to the wall framing. Localised removal of the linings is recommended to identify if the veneer is tied back.
- ▶ If the veneer is found not to be tied back to the wall framing it is recommended that the veneer is either removed and replaced with light weight cladding or is tied back to the framing with masonry ties.
- ▶ The areas adjacent to the unreinforced gable walls should be cordoned off until the above recommendations have been completed.

12. Limitations

12.1 General

This report has been prepared subject to the following limitations:

- No intrusive structural investigations have been undertaken.
- No inspection of the interior of the building was undertaken.
- No intrusive geotechnical investigations have been undertaken.
- No level or verticality surveys have been undertaken.
- No material testing has been undertaken.
- No calculations, other than the wall bracing calculations, shear and moment capacity checks included in this report have been carried out on the structure.

It is noted that this report has been prepared at the request of Christchurch City Council and is intended to be used for their purposes only. GHD accepts no responsibility for any other party or person who relies on the information contained in this report.

12.2 Geotechnical Limitations

The data and advice provided herein relate only to the project and structures described herein and must be reviewed by a competent geotechnical engineer before being used for any other purpose. GHD Limited (GHD) accepts no responsibility for other use of the data by third parties.

Where drill hole or test pit logs, cone tests, laboratory tests, geophysical tests and similar work have been performed and recorded by others under a separate commission, the data is included and used in the form provided by others. The responsibility for the accuracy of such data remains with the issuing authority, not with GHD.

The advice tendered in this report is based on information obtained from the desk study investigation location test points and sample points. It is not warranted in respect to the conditions that may be encountered across the site other than at these locations. It is emphasised that the actual characteristics of the subsurface materials may vary significantly between adjacent test points, sample intervals and at locations other than where observations, explorations and investigations have been made. Subsurface conditions, including groundwater levels and contaminant concentrations can change in a limited time. This should be borne in mind when assessing the data.

It should be noted that because of the inherent uncertainties in subsurface evaluations, changed or unanticipated subsurface conditions may occur that could affect total project cost and/or execution. GHD does not accept responsibility for the consequences of significant variances in the conditions and the requirements for execution of the work.

The subsurface and surface earthworks, excavations and foundations should be examined by a suitably qualified and experienced Engineer who shall judge whether the revealed conditions accord with both the assumptions in this report and/or the design of the works. If they do not accord, the Engineer shall modify advice in this report and/or design of the works to accord with the circumstances that are revealed.

An understanding of the geotechnical site conditions depends on the integration of many pieces of information, some regional, some site specific, some structure specific and some experienced based. Hence this report should not be altered, amended or abbreviated, issued in part and issued incomplete in any way without prior checking and approval by GHD. GHD accepts no responsibility for any circumstances which arise from the issue of the report which have been modified in any way as outlined above.

Appendix A
Photographs

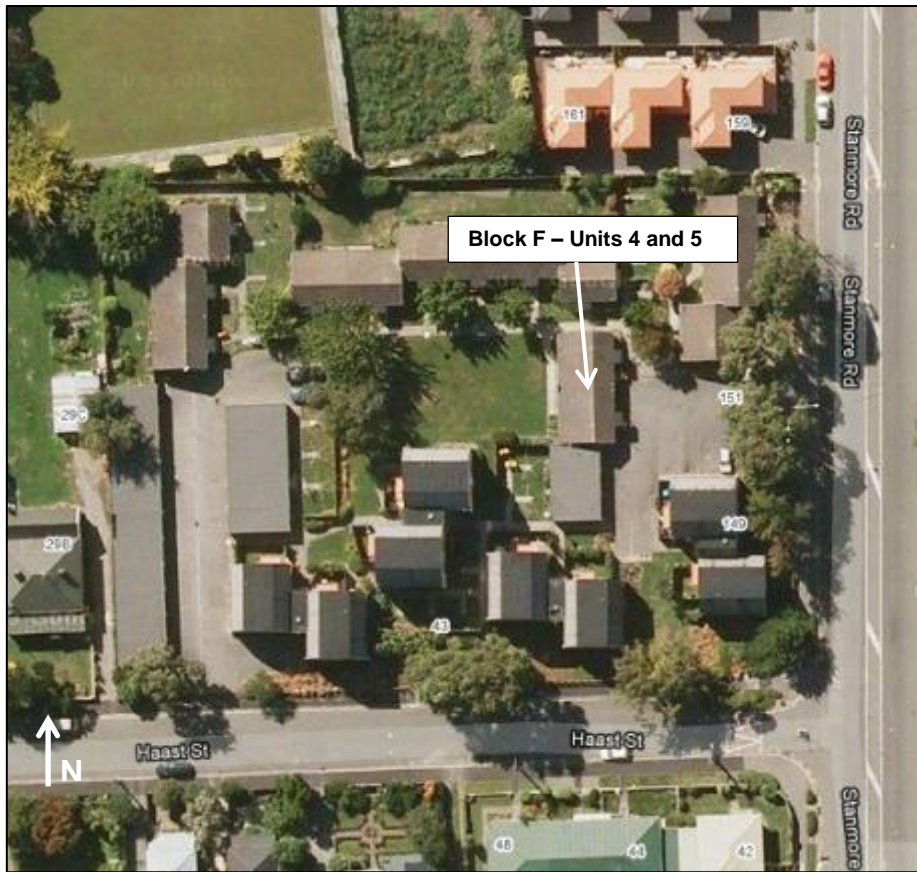

Photo 1 Aerial photograph showing location of Haast Courts Block F.



Photo 2 Rear View (West of the building).



Photo 3 Front View (East of the building).



Photo 4 Front View (East of the building).



Photo 5 Southern gable of the building adjoining garage Block K.



Photo 6 Minimal gap between buildings filled with flexible seal.

Appendix B
Existing Drawings

14 UNITS
STANIMORE

ROAD

**HELDERLY
EPHSONG
PHOSING**

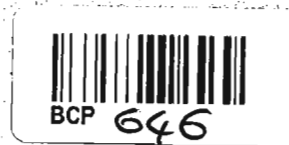

CHRISTCHURCH CITY COUNCIL
Approved Subject to the By-Laws
11 OCT 1978
For City Engineer

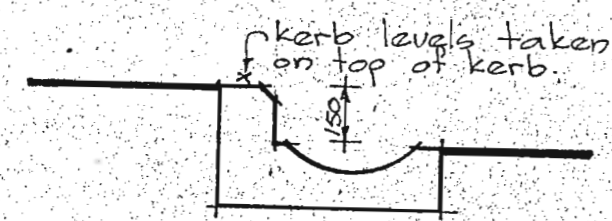

detail Stanmore Road
dished kerb & channel

- ⊙ existing levels
- ◇ new levels

LEVELS

All levels are in terms of C.D.B. and C.C.C. datum. Reference bench mark for these site levels shall be the North-East corner of the northernmost sewer manhole at the intersection of Stanmore Road and Haast Street.

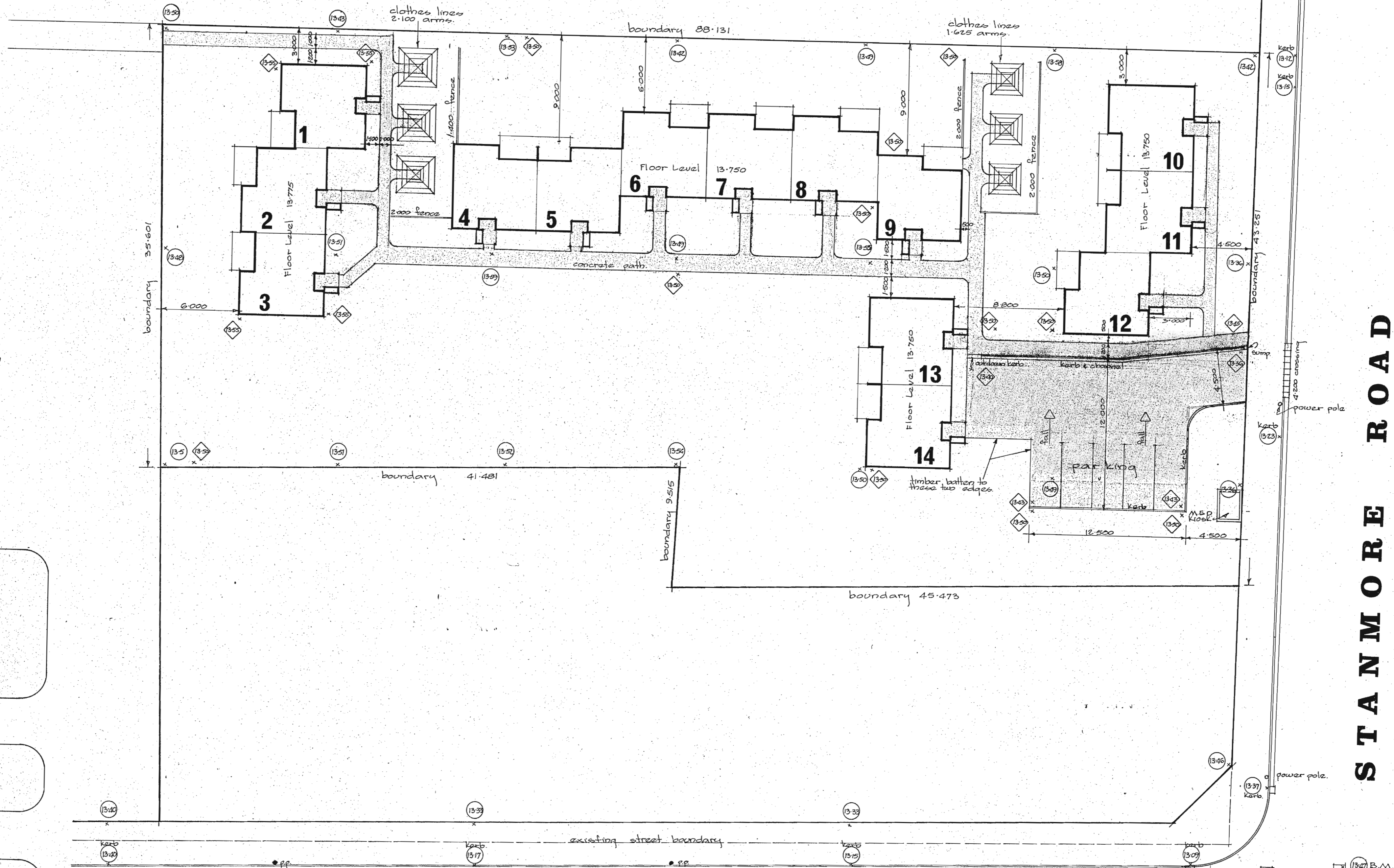

H A A S T S T R E E T

S T A N M O R E R O A D

S I T E P L A N

ELDERLY PERSONS HOUSING

CHRISTCHURCH

14 UNITS STANMORE ROAD FOR M. L. PAYNTER LTD.

9.9.78 Entry porches added
9.9.78 Pathway Stanmore Road added
9.9.78 Car parking amended

ELECTRICAL METER BOX TO BE INSTALLED ON OUTSIDE WALL NEAR THE PUBLIC ENTRANCE OR COMMON R.O.W. NOT BEHIND A FENCE 50 mm. DIA. CABLE ENTRY DUCT.

CHRISTCHURCH CITY COUNCIL
Approved Subject to the By-Laws
1 OCT 1978
IAN KRAUSE
P.R. CIVIL ENGINEER

IAN KRAUSE ASSOCIATES

REGISTERED ARCHITECTS Urban Design & Environment Consultants
P.O. Box 1766 Christchurch Phone 60323

Date: JULY 1978
Scale: 1 : 200
Job No: 526
1

waste diameters
 shower 40 mm
 basin 32 mm
 tub 40 mm
 sink 40 mm

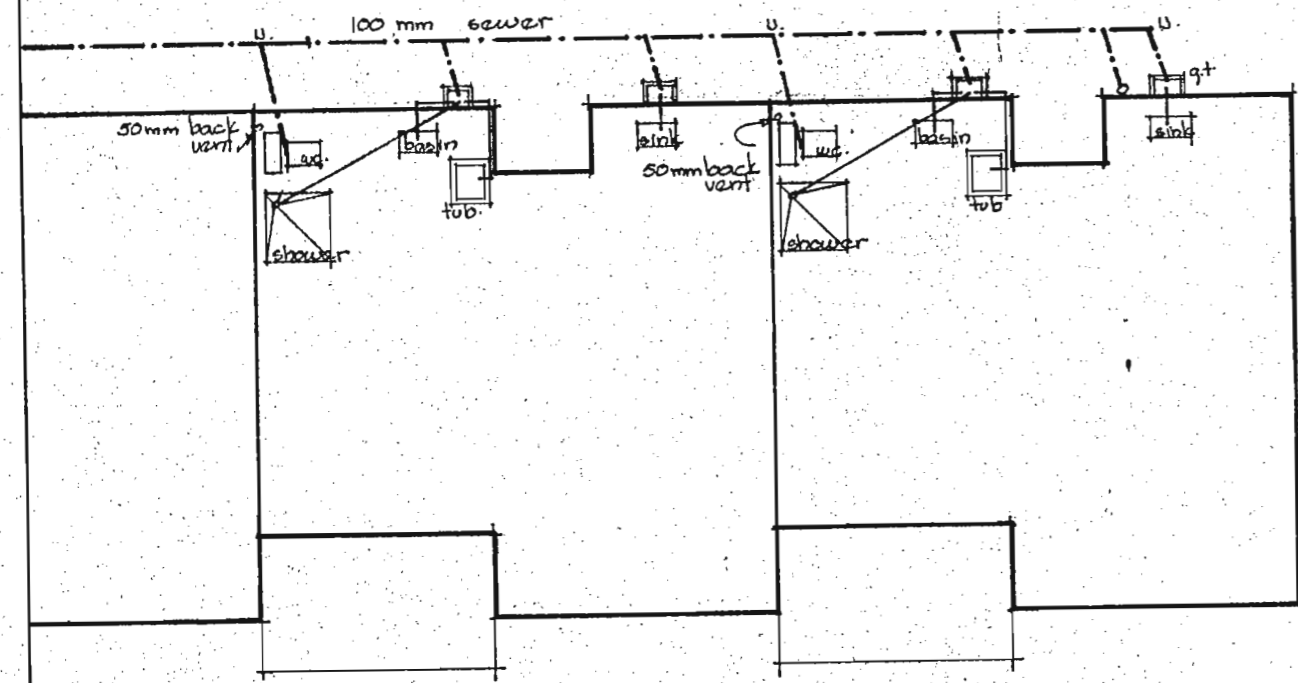

plumbing layout
 typical units

SERVICES LEGEND

- 100 mm stormwater drain
- 100 mm sewer drain
- H.P. cold water supply
- gate valve on H.P. water supply to main supply lines
- 13 mm supply to each unit run in chase left on outside of foundation. Fit stopcock in this location.
- 100 mm sewer with concrete cover
- Note: Electrical supply to each unit run in same line as H.P. cold water supply.
- hose tap total No 6

LEVELS

Refer to sheet 1 for additional new and existing levels and levels of parking area.
 All levels are in terms of CDB and C.C. datum.

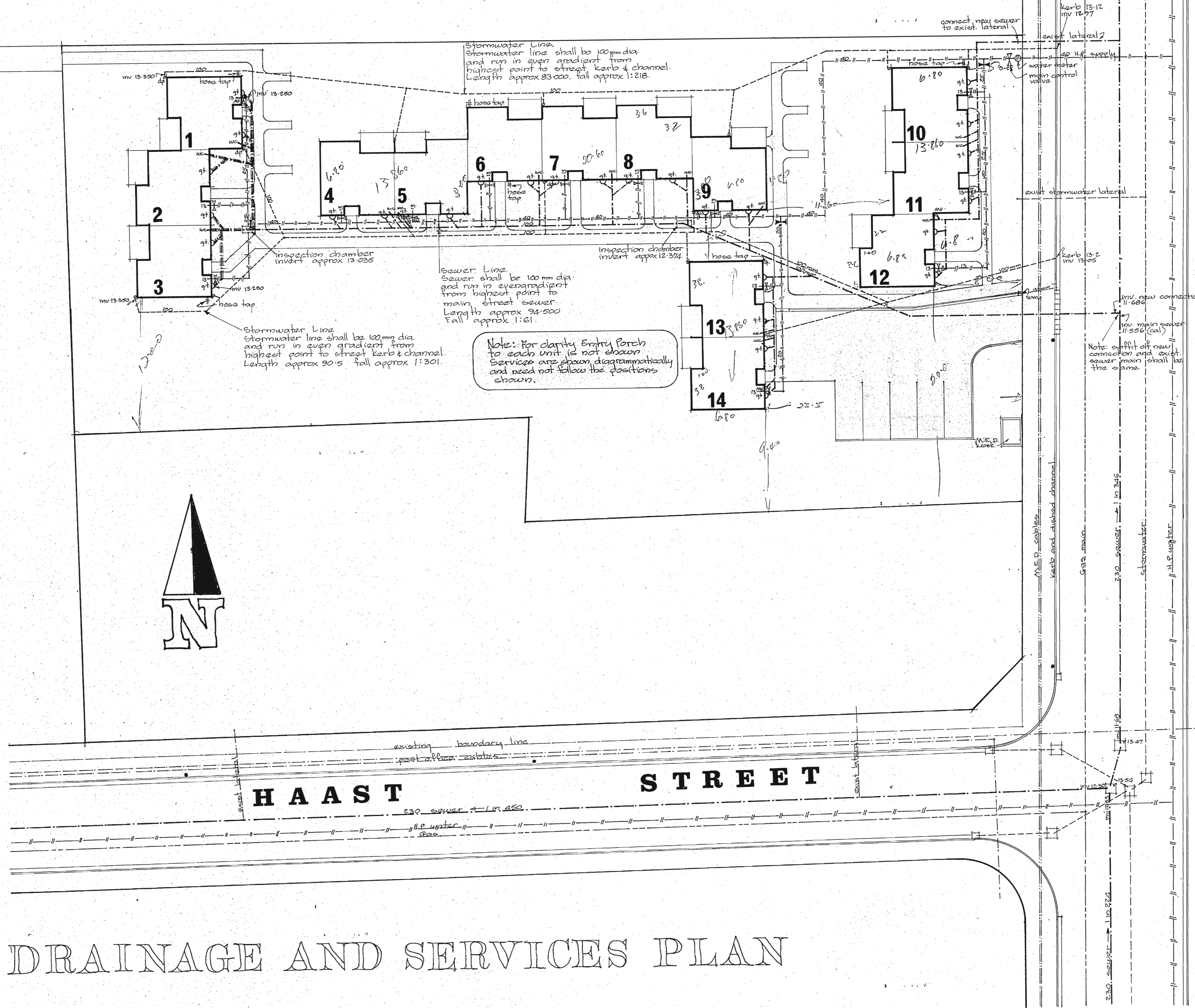

DRAINAGE AND SERVICES PLAN

ELDERLY PERSONS HOUSING
 CHRISTCHURCH 14 UNITS STANMORE ROAD FOR M. L. PAYNTER. LTD

CITY ENGINEER CITY COUNCIL
 Approved Subject to the By-Laws
 11 OCT 1978
 For City Engineer

Date: JULY 1978
 Scale: 1 : 200
 Job No: 526
 2

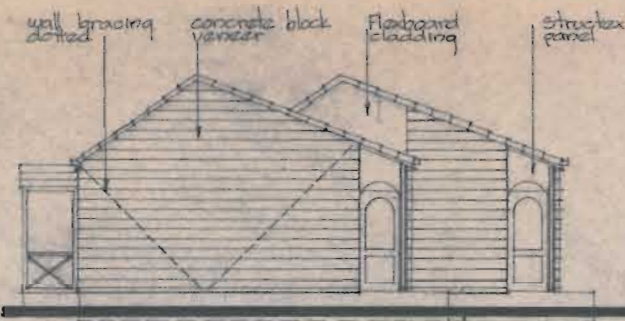

EAST

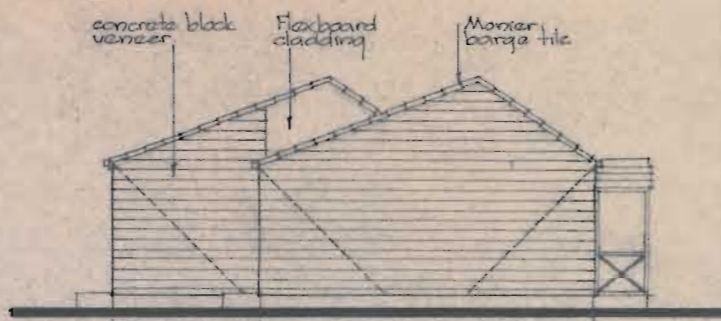

WEST

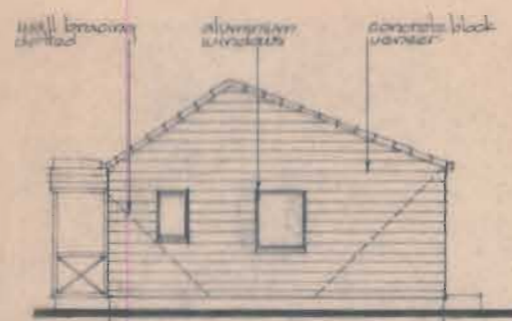

NORTH

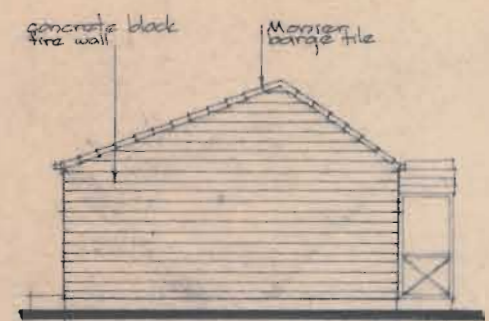

SOUTH

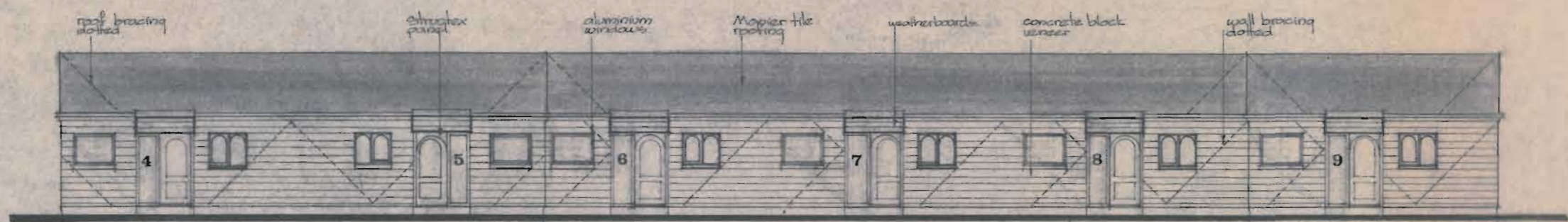

SOUTH

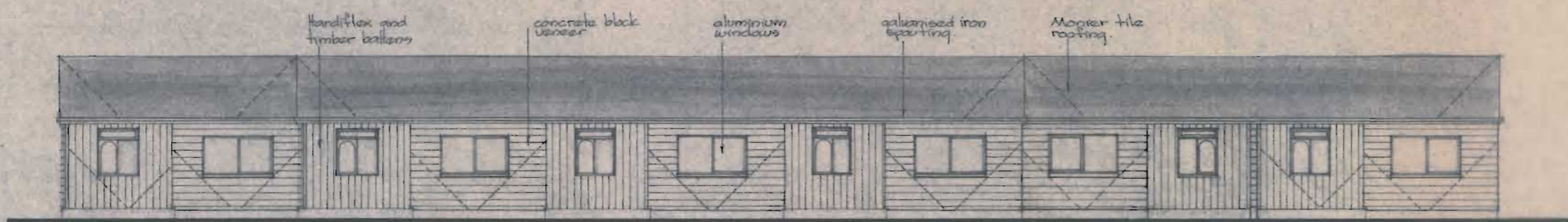

NORTH

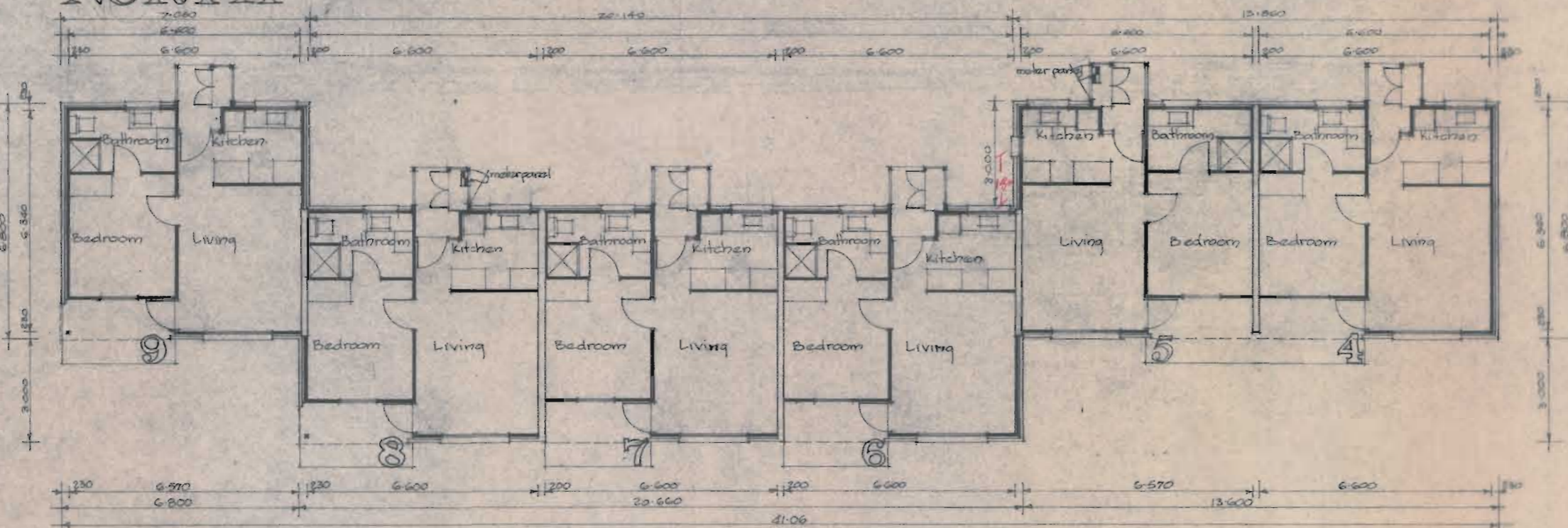

PLAN

UNITS 4 - 9

Note: see sheet 5 for detailed dimensions of floor plans.

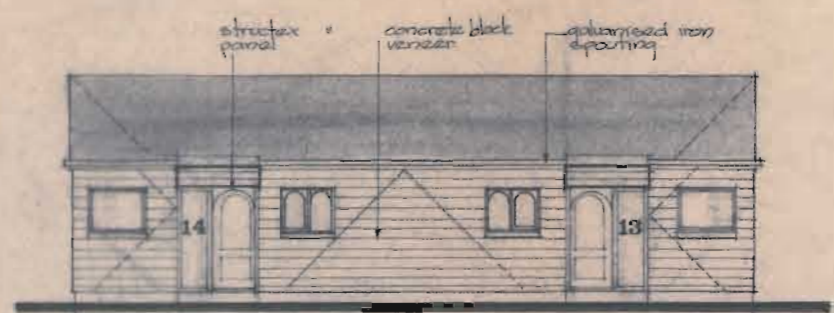

EAST

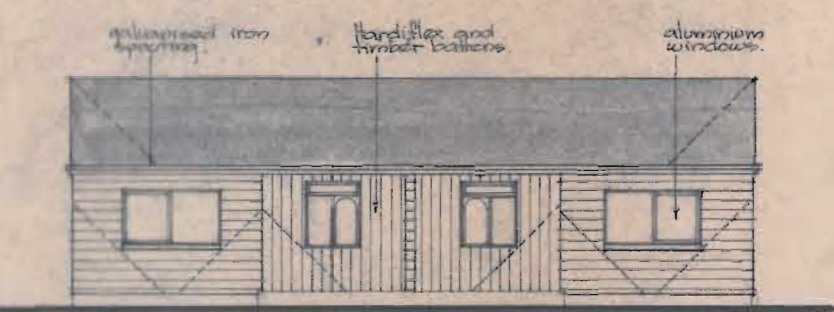

WEST

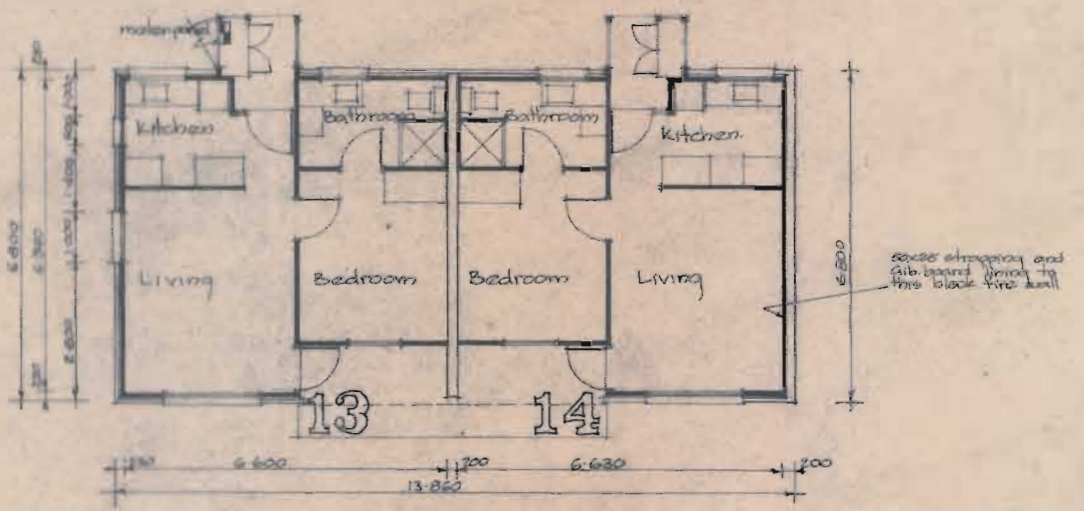

PLAN

UNITS 13 - 14

Approved by the City Engineer
11 OCT 1978

ELDERLY PERSONS HOUSING

CHRISTCHURCH

14 UNITS STANMORE ROAD FOR M. L. PAYNTER LTD

10-3-78 Existing parties visited for access control.
10-9-78 Draft No 2 prepared & submitted to Council.
10-12-78 Resubmission submitted.
10-7-78 Draft revised & resubmitted.

IAN KRAUSE ASSOCIATES REGISTERED ARCHITECTS (Urban Design & Environment Consultants)
P.O. Box 1768 Christchurch Phone 60323

Date: JULY 1978
Scale: 1:100
Job No: 525
3

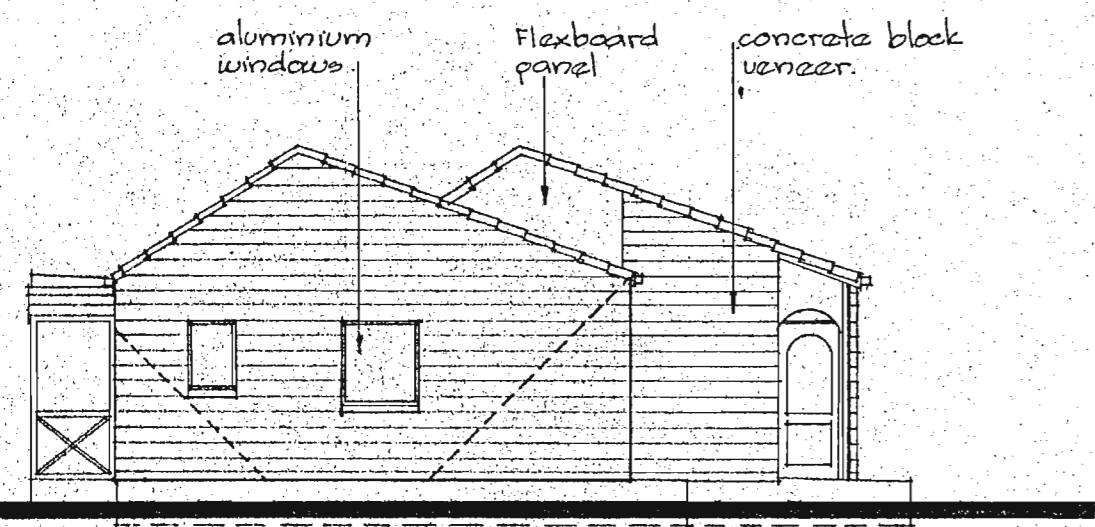

NORTH

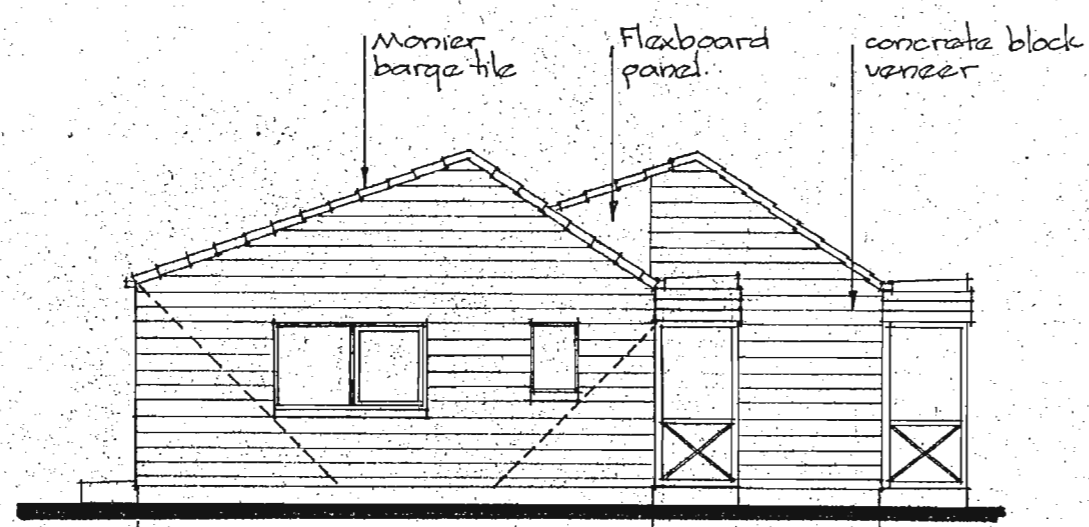

SOUTH

Note: North and South elevations of units 10-12 are the same as units 1-3 opposite.

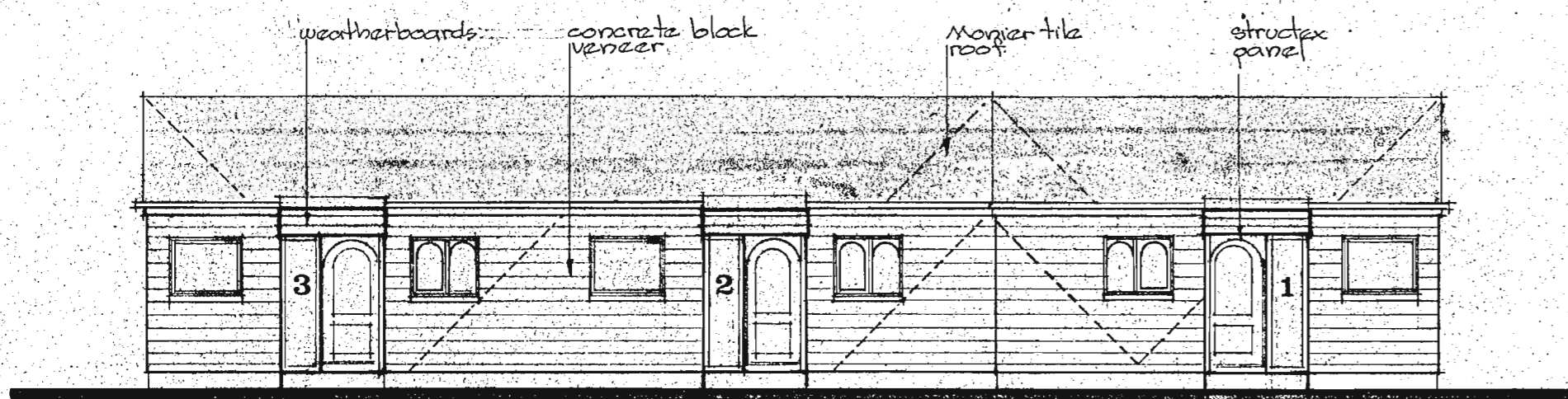

EAST

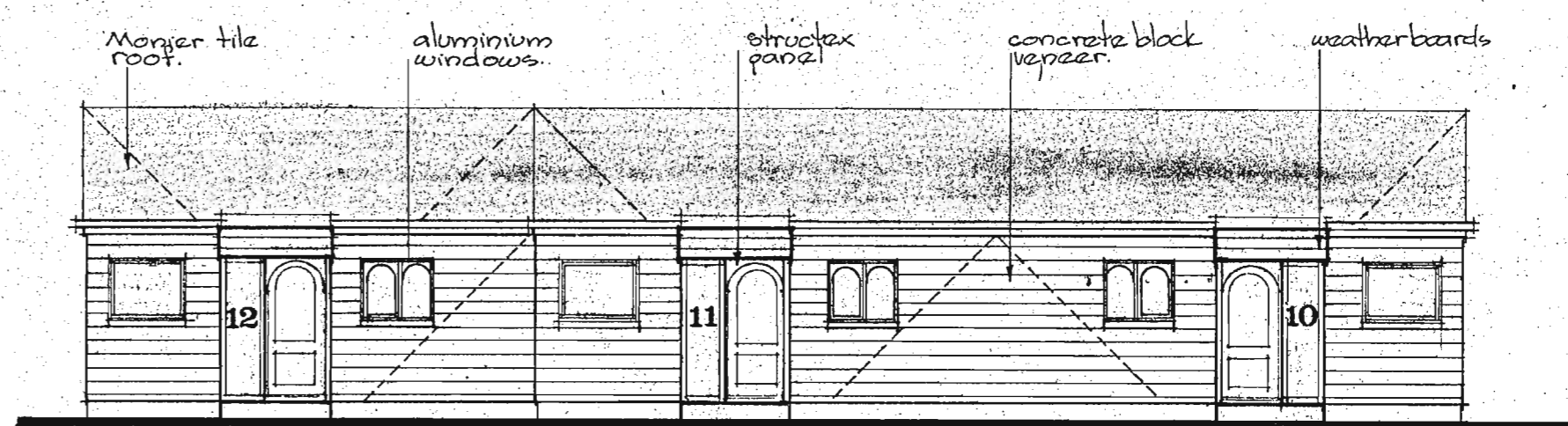

EAST

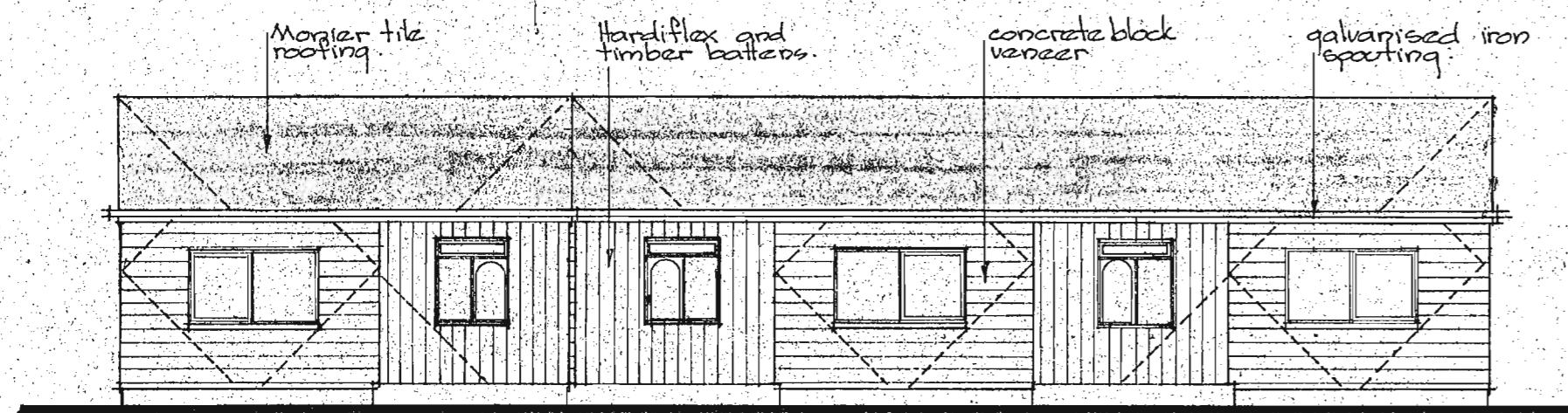

WEST

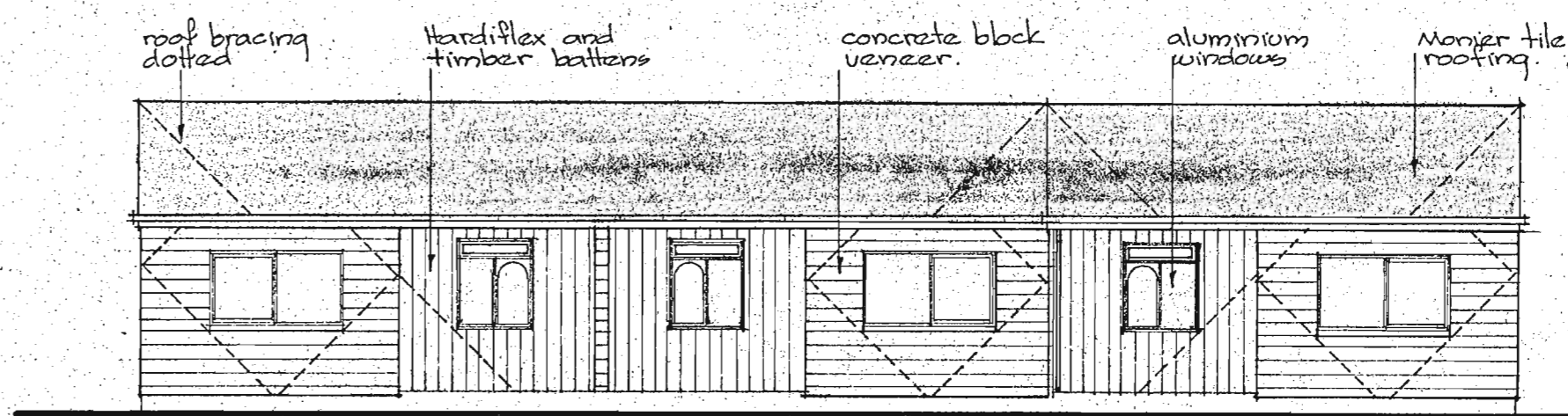

WEST

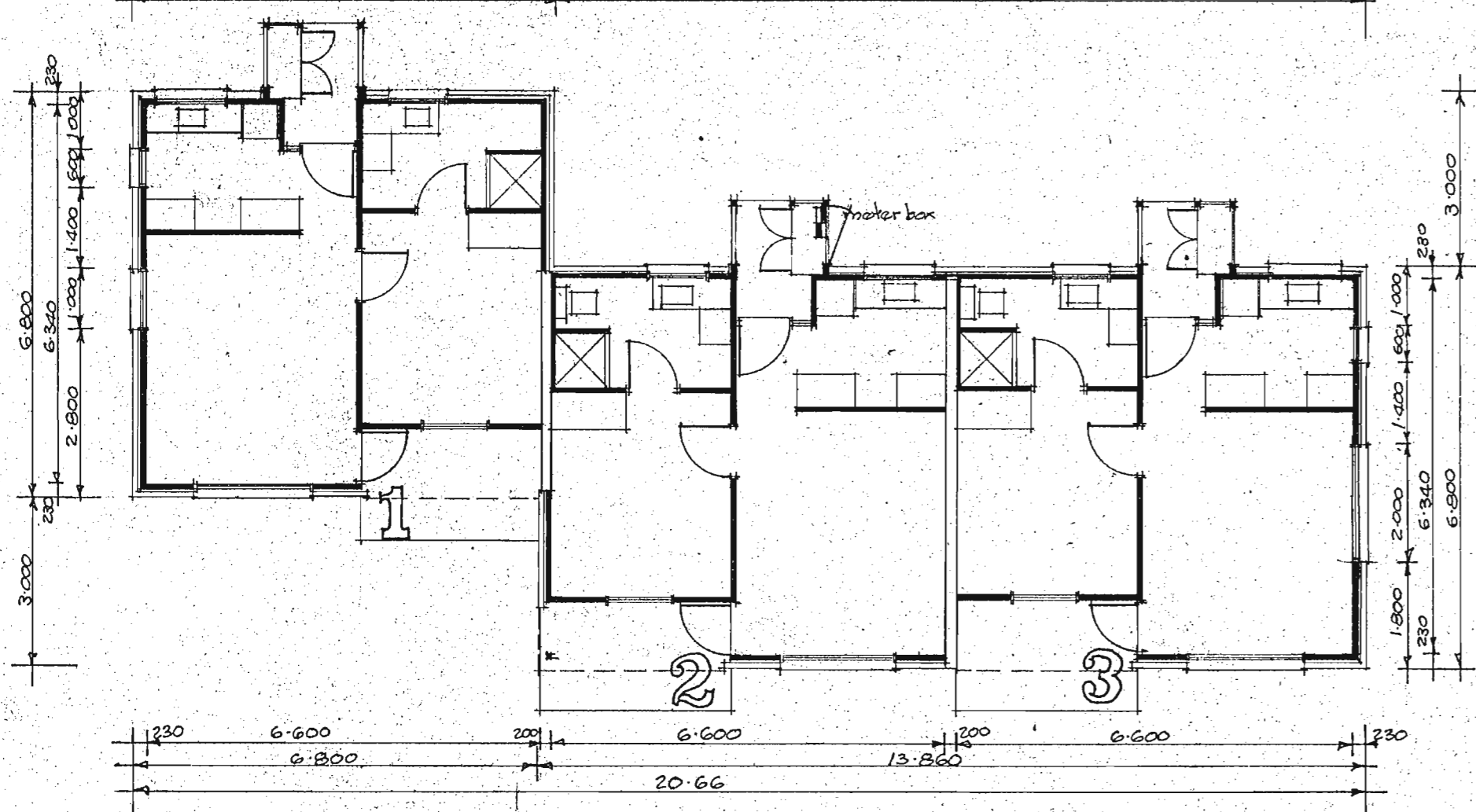

PLAN

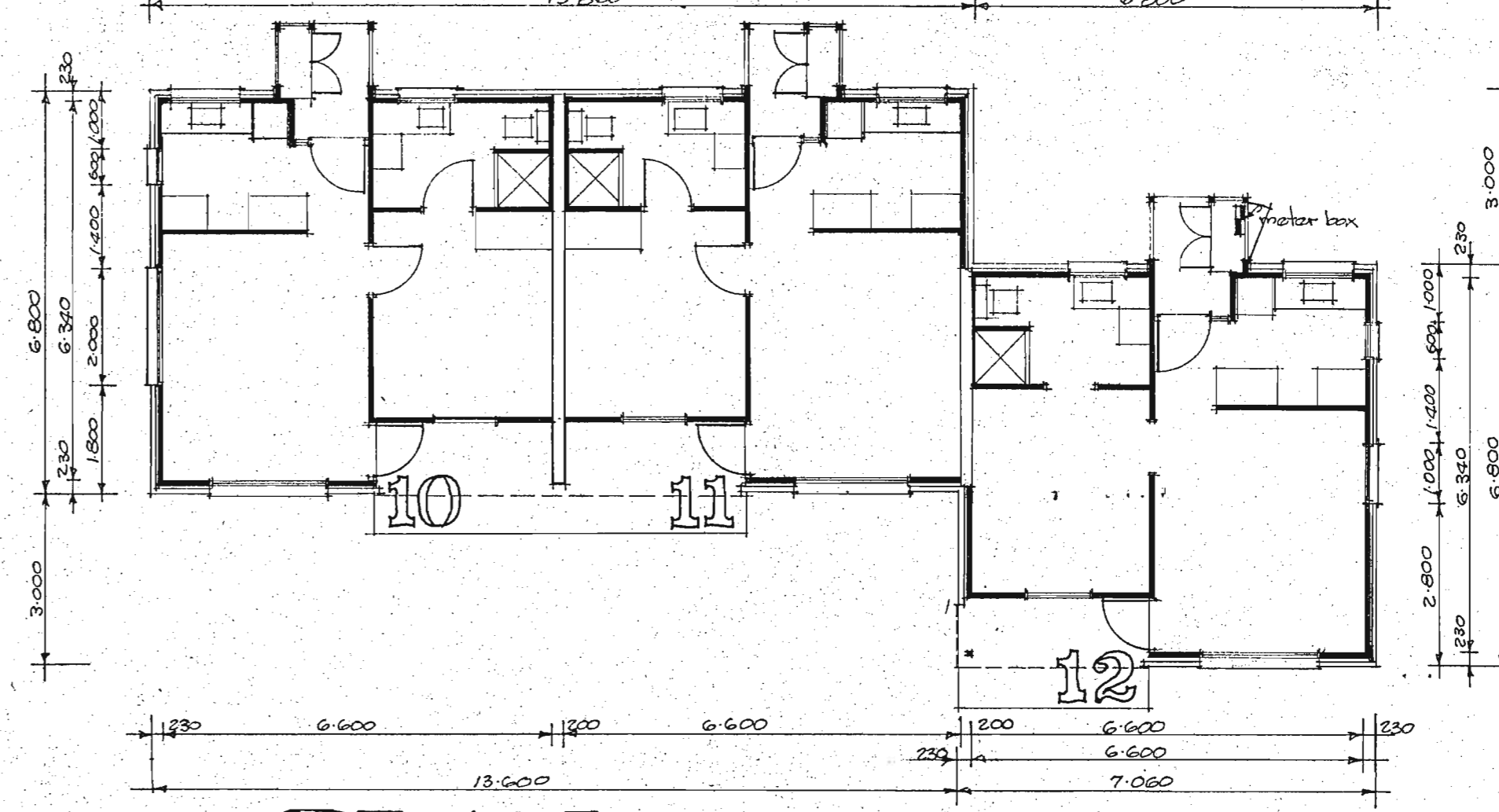

PLAN

UNITS 1-3

UNITS 10-12

Approved for the City of Christchurch
11 OCT 1978
For City Engineer

ELDERLY PERSONS HOUSING

CHRISTCHURCH

14 UNITS STANMORE ROAD FOR M. L. PAYNTER LTD

- 9.9.78 Entry porch added to each unit
- 9.9.78 bathroom window boarded
- 9.9.78 pink bench and range painted
- 9.9.78 larger window to Unit 3 added

IAN KRAUSE ASSOCIATES REGISTERED ARCHITECTS Urban Design & Environment Consultants P.O. Box 1768 Christchurch Phone 60323

Date: JULY 1978
Scale: 1:100
Job No: 526
4

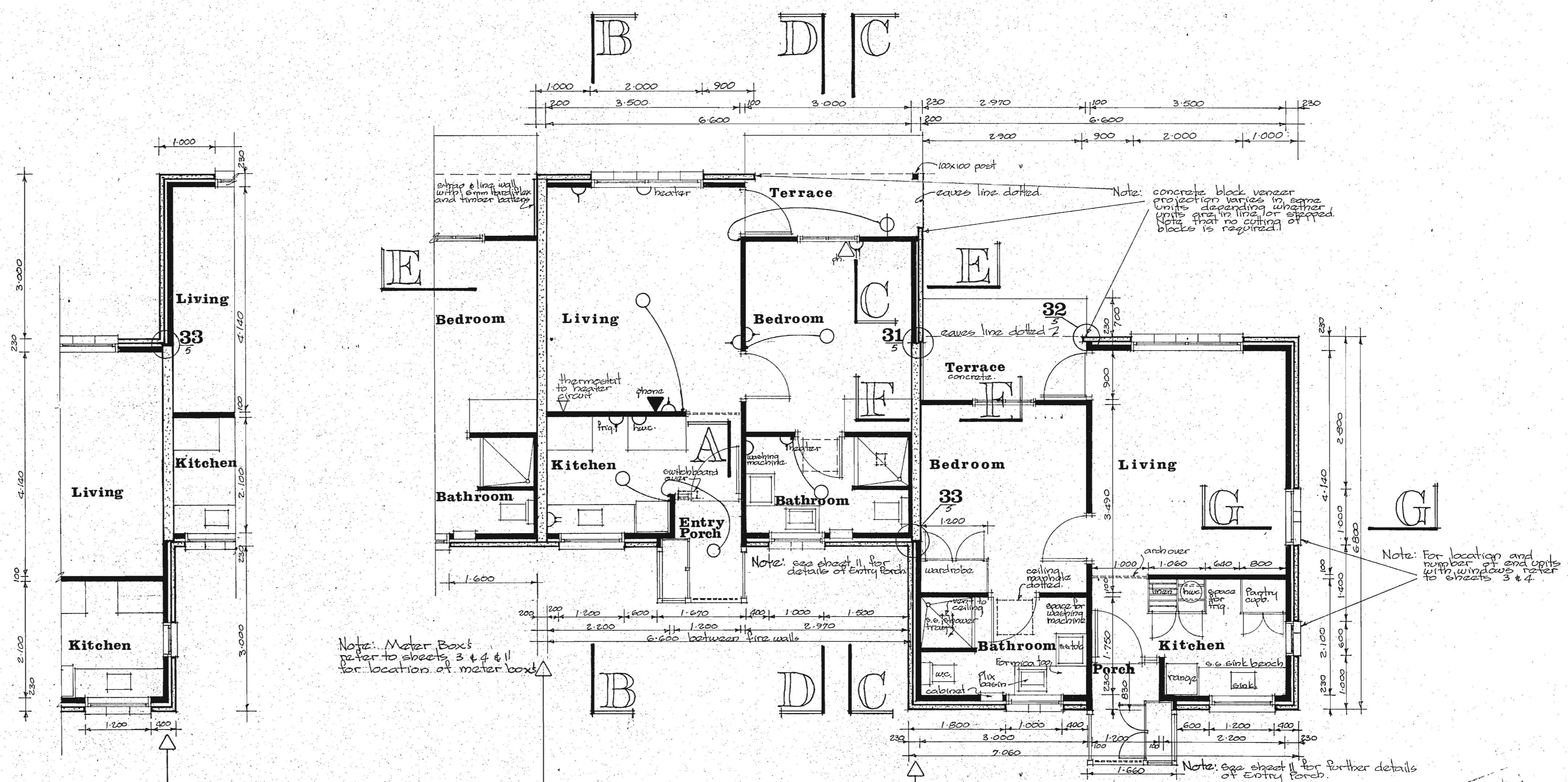
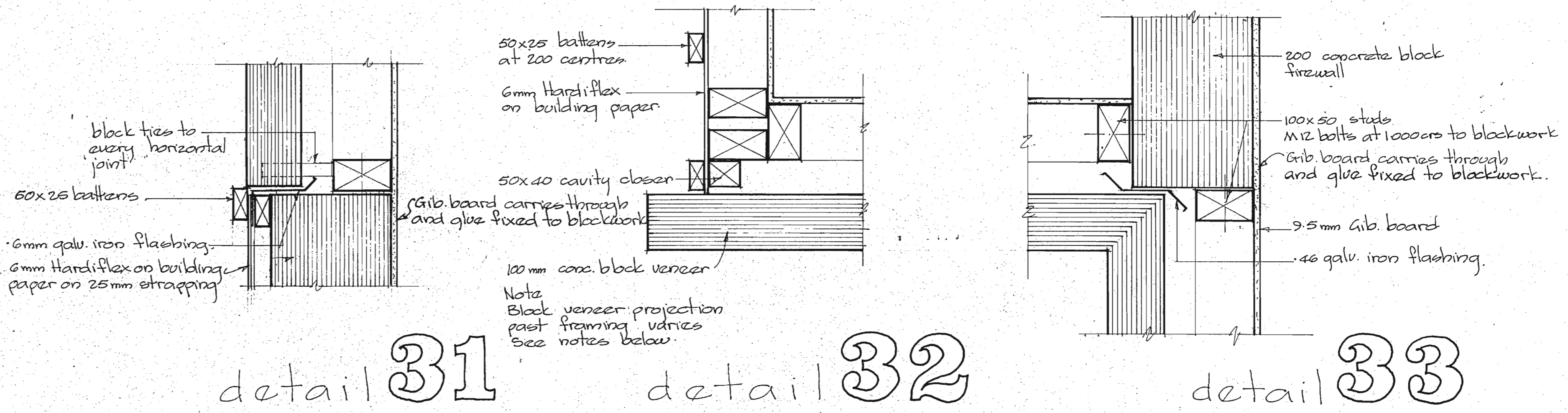

- ELECTRICAL LEGEND**
- pendant light
 - ⊕ wall bracket light
 - ⊡ single switched power point
 - ⊡ double switched power point
 - ⊡ fixed connection with switch
 - ⊡ wall light switch
 - ◀ phone outlet
 - ◁ phone jack point
- Heaters:
heater points as shown on electrical plan are for the following types of heaters:
Living 3 kw Sirocco Fantasy heater
Bathroom Fixed radiant convection heater.

fire wall between units 5 & 6 typical fire wall between units in line electrical plan and typical plan to intermediate units typical firewall between stepped units typical floor plan to end units

Approved Subject to the Bylaws
11 OCT 1978
For City Engineer

TYPICAL FLOOR PLANS

ELDERLY PERSONS HOUSING

CHRISTCHURCH

14 UNITS STANMORE ROAD FOR M. L. PAYNTER LTD

Date: JULY 1978
Scale: 1:50
Job No: 526
5

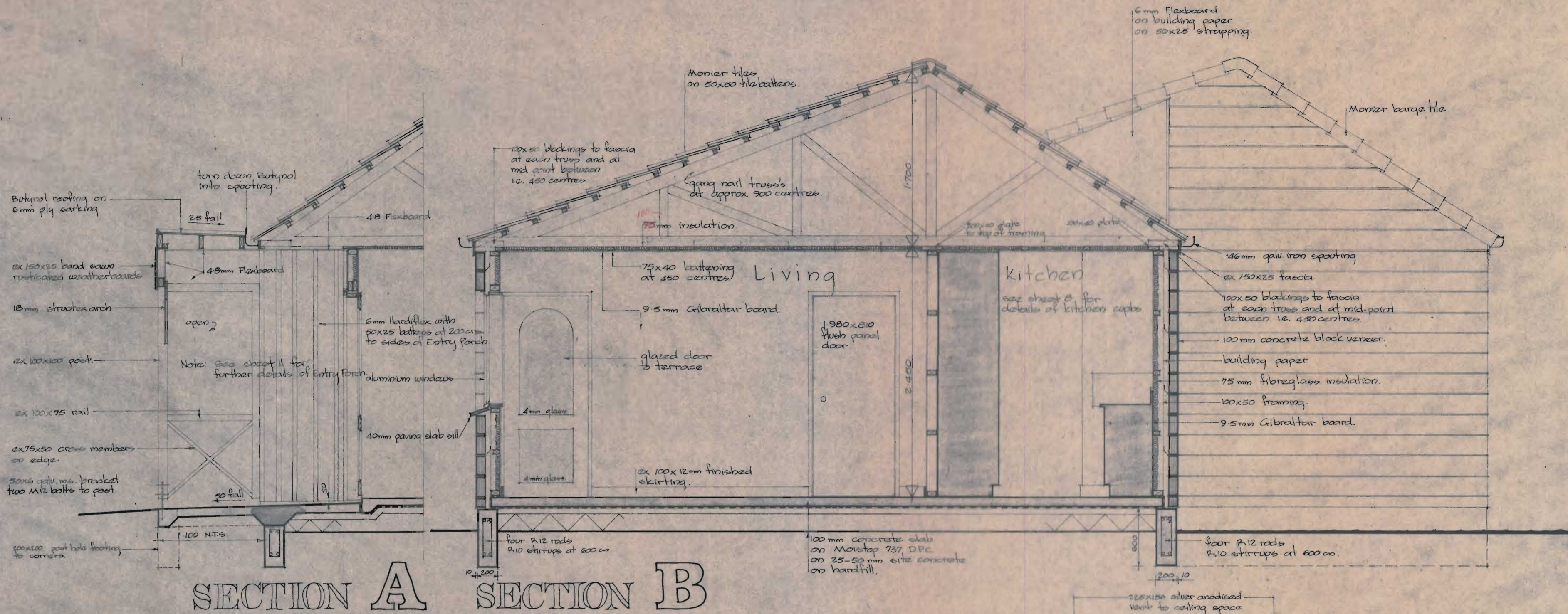

SECTION A SECTION B

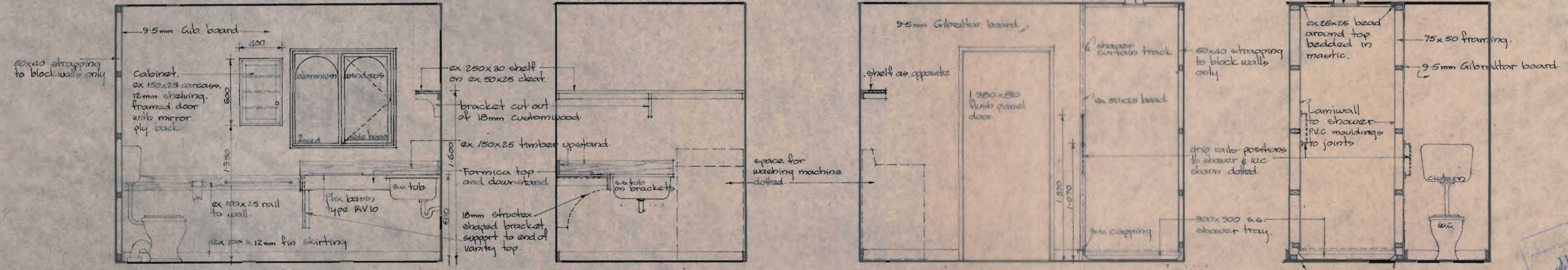

Bathroom wall elevations

Note: Bathroom wall elevations to units 1, 13 and 10 shall be the same but handed.

ELDERLY PERSONS HOUSING

CHRISTCHURCH

14 UNITS STANMORE ROAD FOR M L PAYNTER LTD

11 OCT 1978
For City Engineer

Issue: JULY 1978
Scale: 1:20
Job No: 526
6

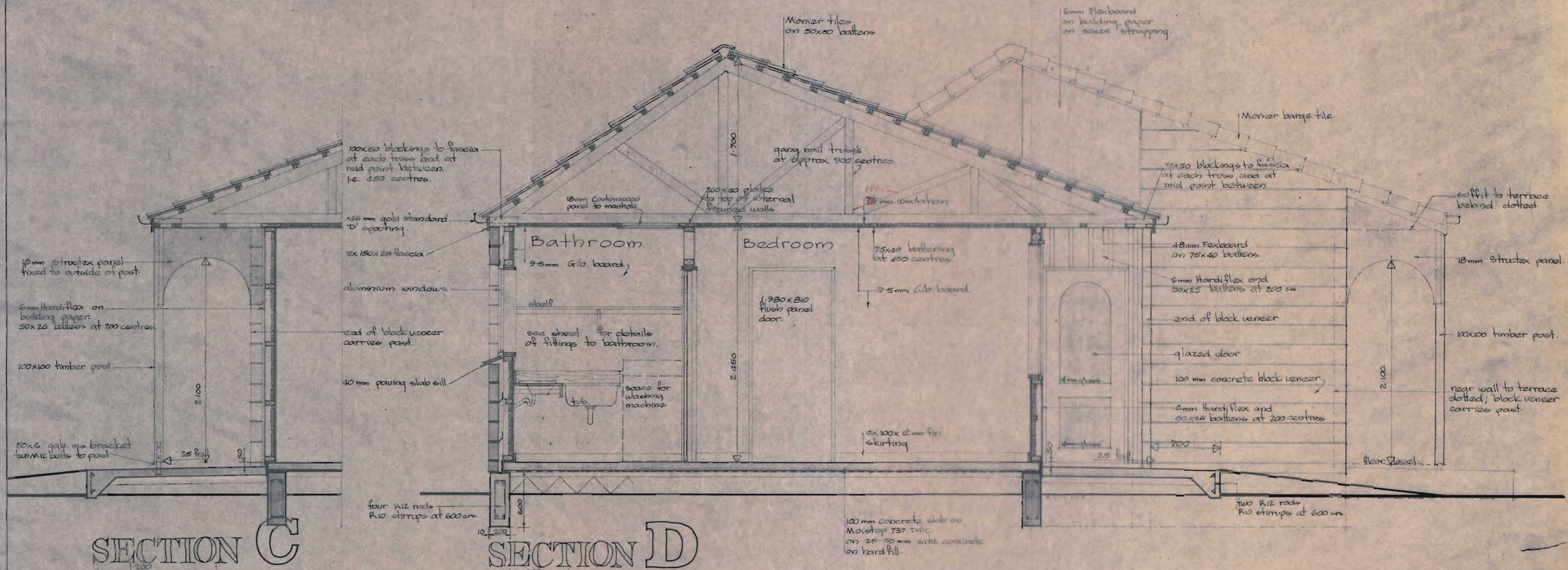

SECTION C

SECTION D

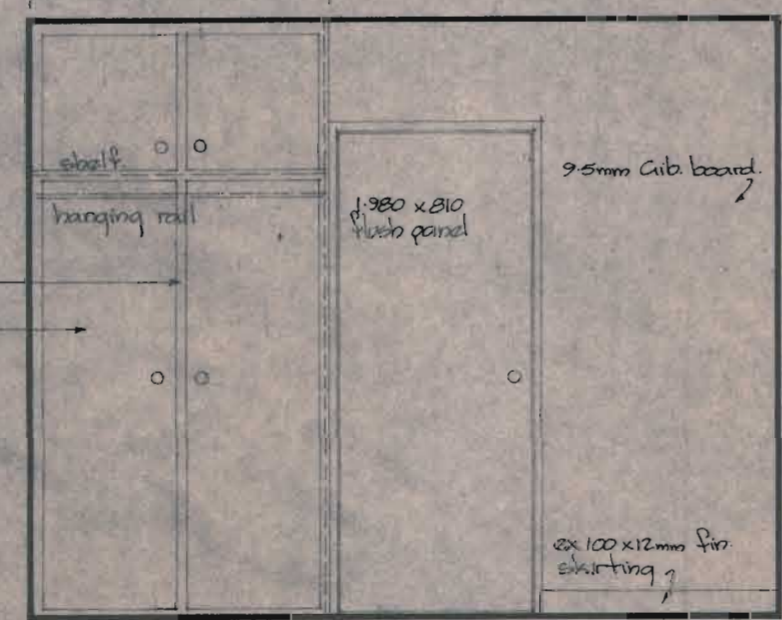

elevation

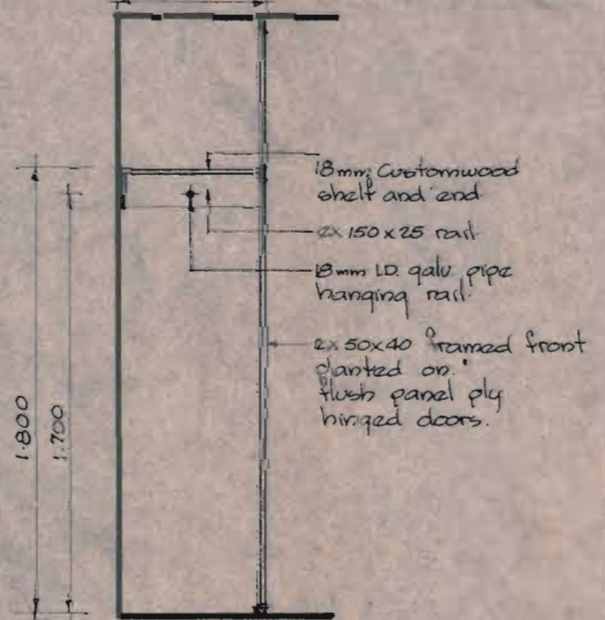

section

Wardrobe to bedrooms and elevation of rear wall

Note: Elevations of rear wall to bedrooms of units 1, 13 and 10 shall be the same but hatched

ELDERLY PERSONS HOUSING

CHRISTCHURCH

14 UNITS STANMORE ROAD FOR M L PAYNTER LTD



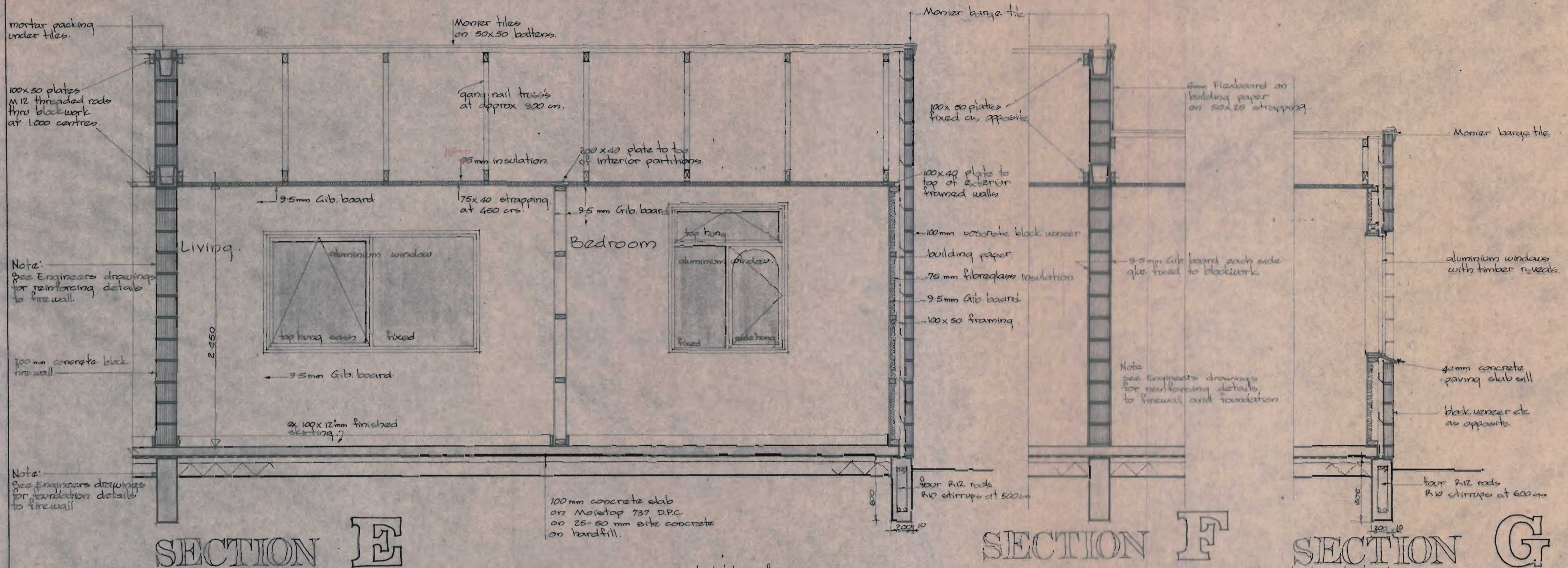

SECTION E

SECTION F

SECTION G

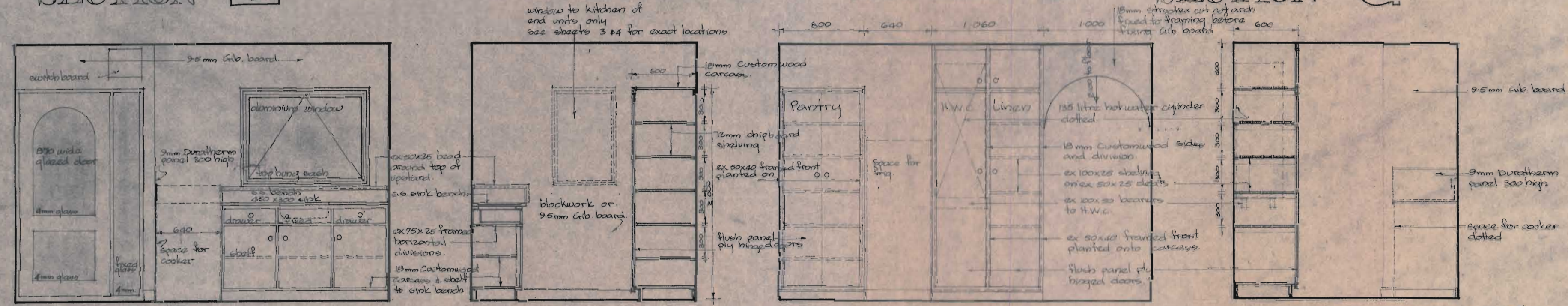

Kitchen wall elevations

Note: Kitchen wall elevations to units 1, 5, 10, and 13 shall be the same but banded.

CHRISTCHURCH CITY COUNCIL
Approved Solution to the By-laws
11 OCT 1978
For City Engineer

ELDERLY PERSONS HOUSING

CHRISTCHURCH

14 UNITS STANMORE ROAD FOR M. L. PAYNTER LTD

Case No. 111 Y 1978
Scale: 1:20
No. 526
8

IAN KRAUSE ASSOCIATES
ARCHITECTS Urban Design & Environment Consultants
P.O. Box 11465 Christchurch Phone 60323

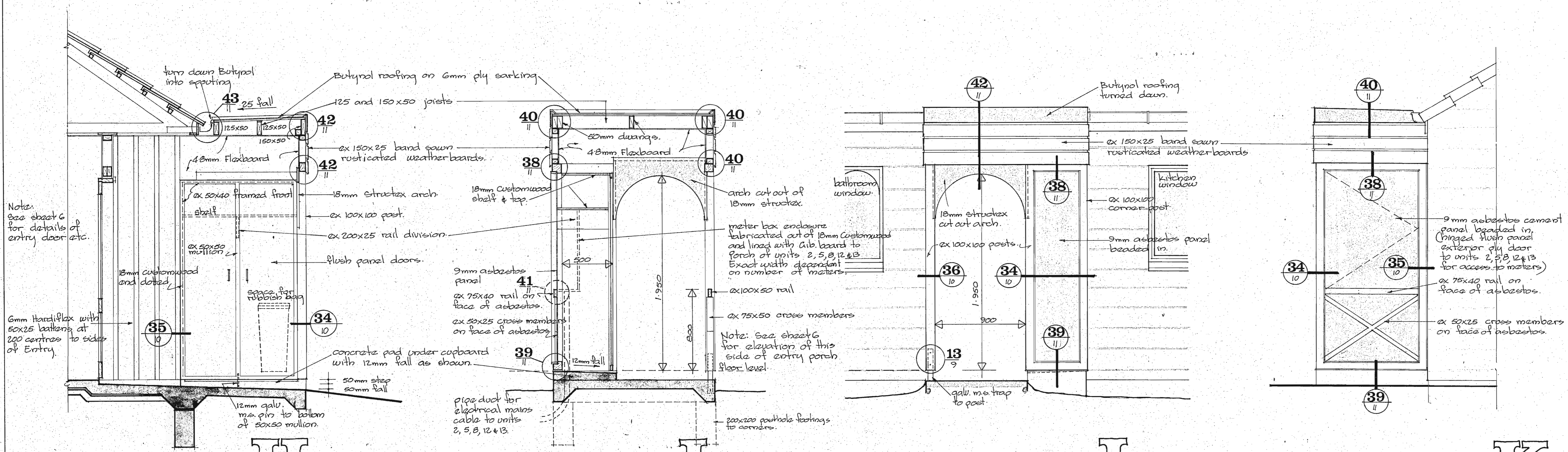

SECTION H

SECTION I

ELEVATION J

ELEVATION K

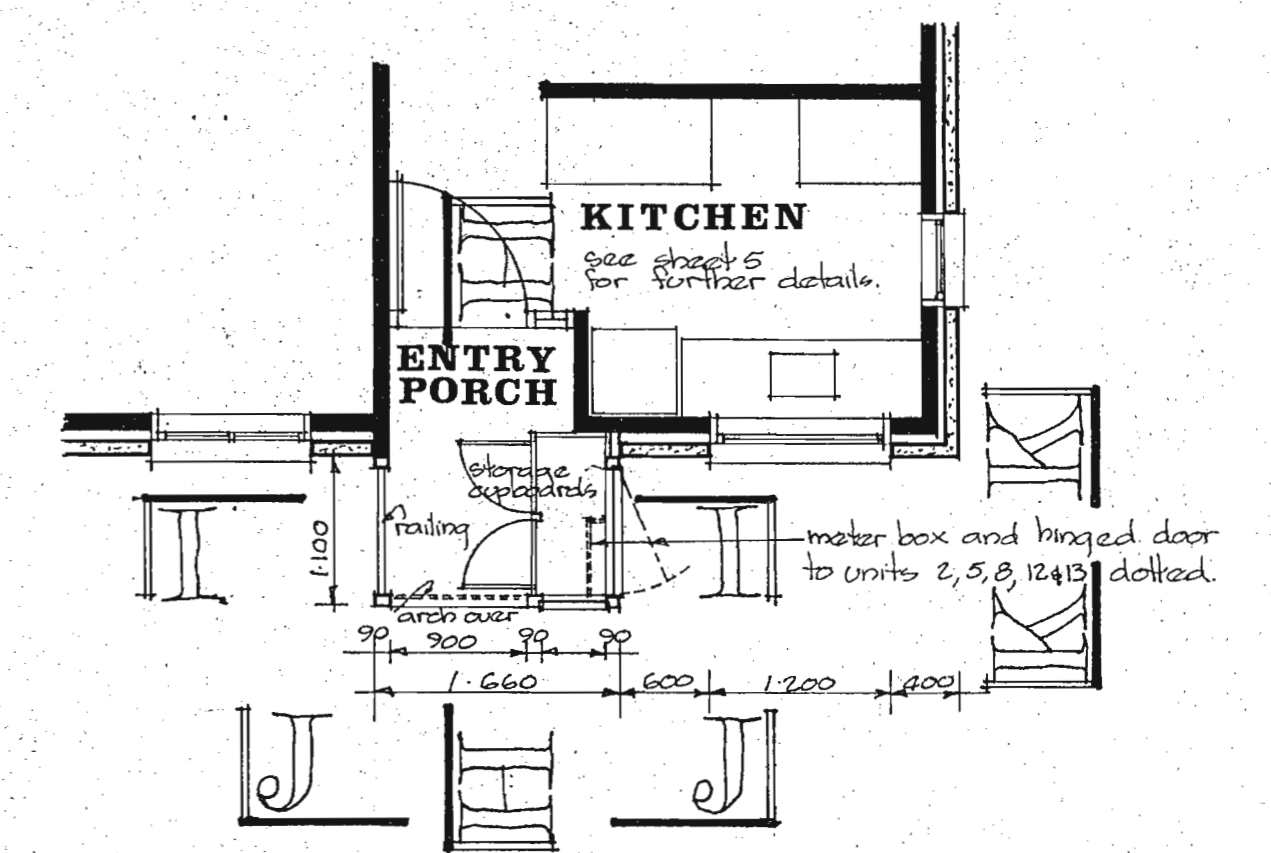
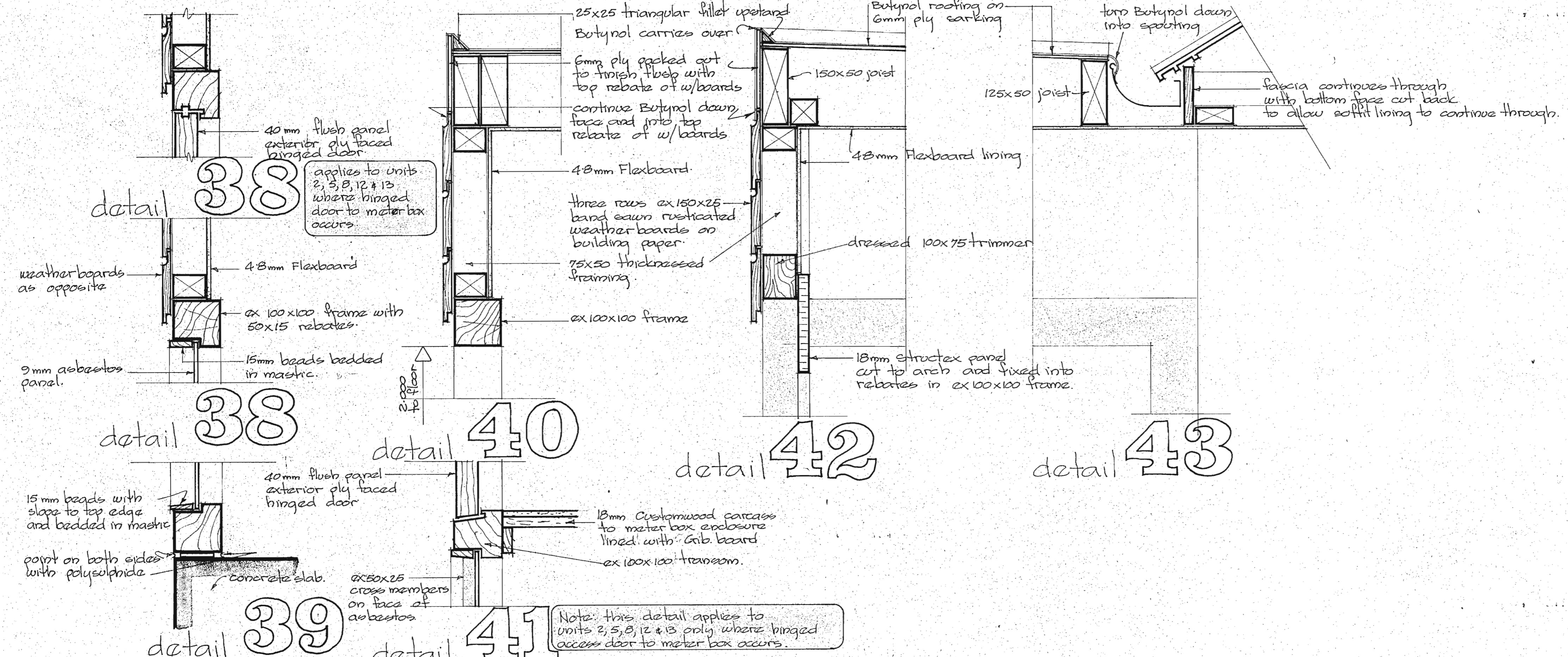

plan entry porch and storage cupboards

CHRISTCHURCH CITY COUNCIL
 Approved Subject to the By-Laws
 10 OCT 1978
 For City Engineer

ELDERLY PERSONS HOUSING

CHRISTCHURCH 14 UNITS STANMORE ROAD FOR M. L. PAYNTER LTD

10-9-78 details added
 10-9-78 meter box enclosure added

IAN KRAUSE ASSOCIATES
 REGISTERED ARCHITECTS Urban Design & Environment Consultants
 P.O. Box 1756 Christchurch Phone 60323

Date: AUG 1978
 Scale: 1:20 1:50
 Job No: 526

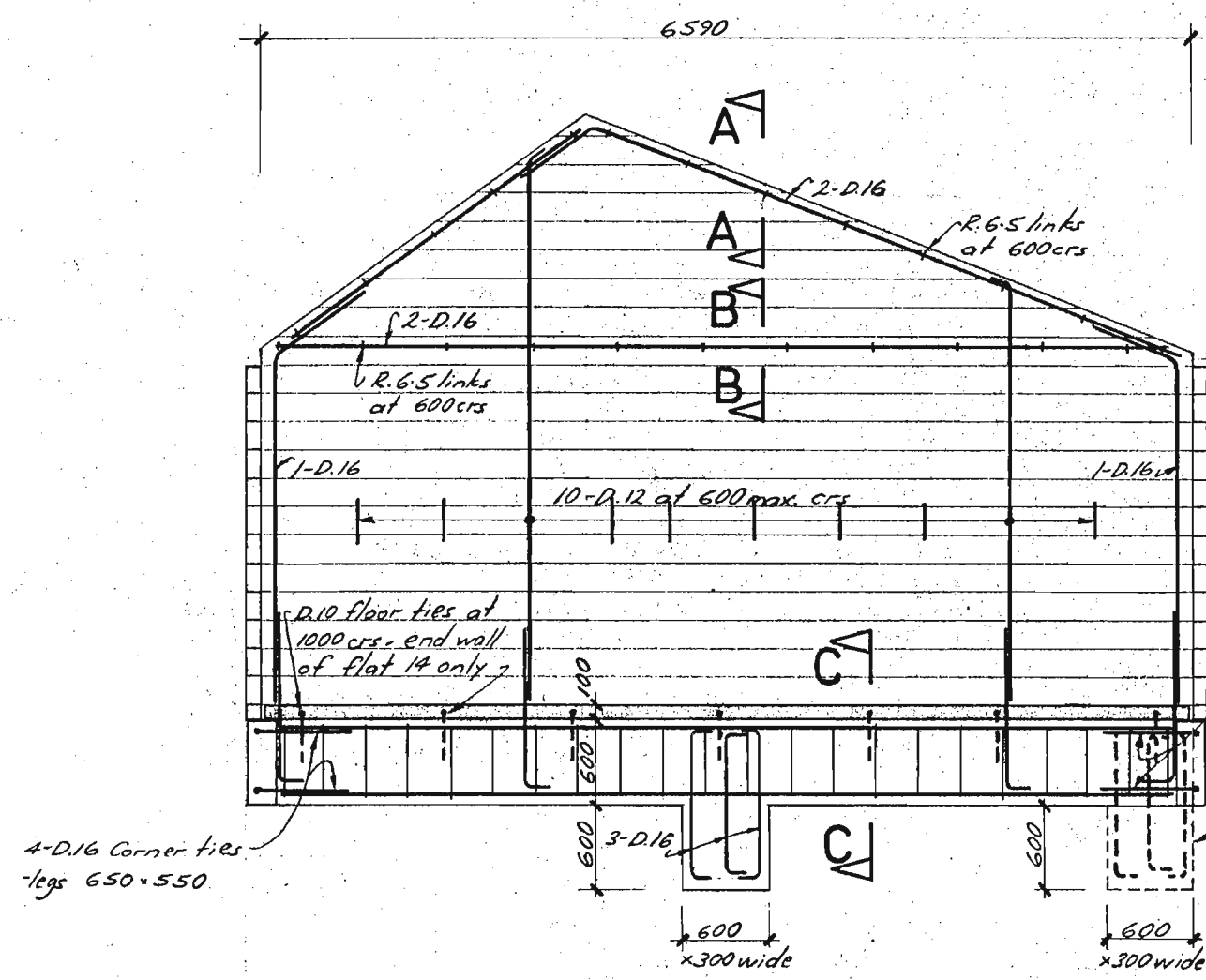

**ELEVATION OF FIREWALL
BETWEEN FLATS 2-3, 4-5, 6-7, 7-8
(10-11, 13-14)**
1:50
Also end wall of flat 14

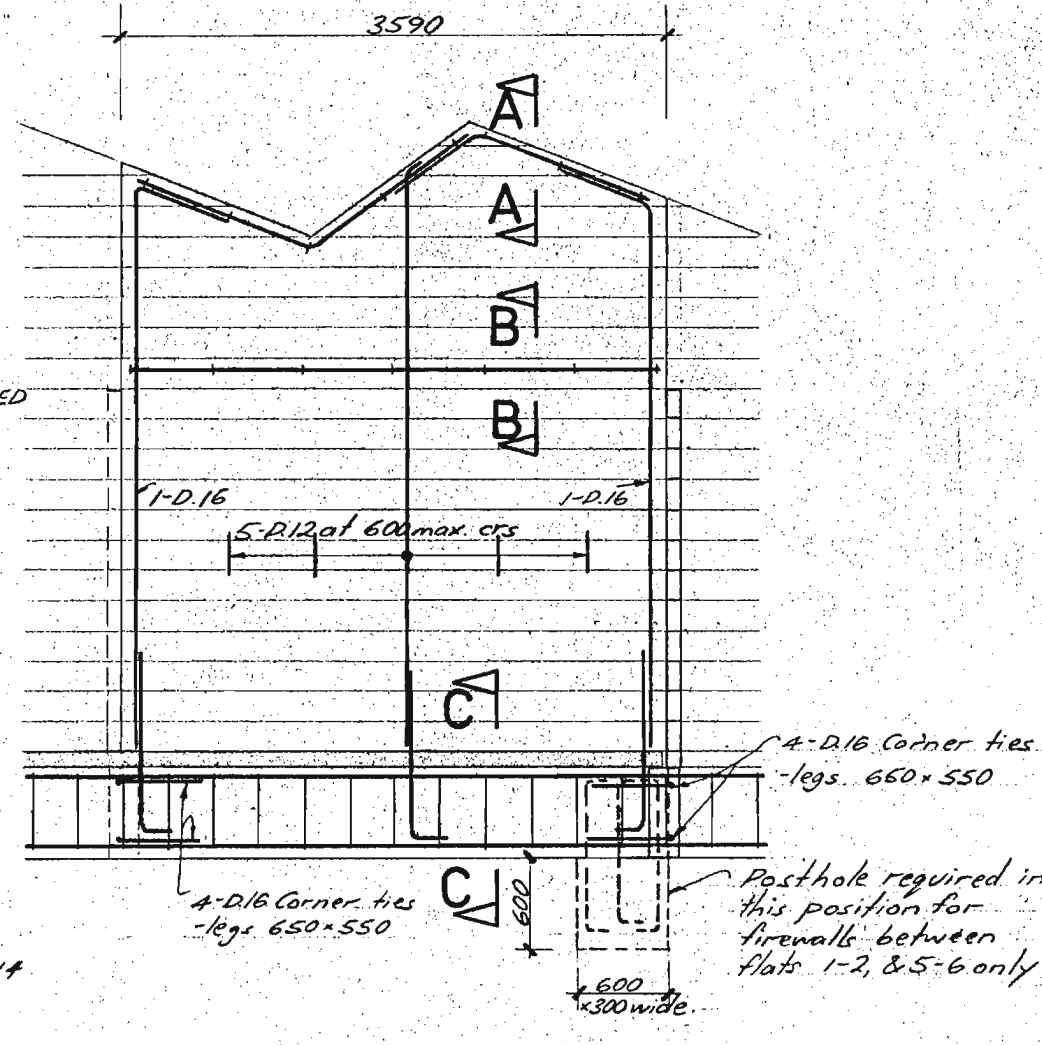

**ELEVATION OF FIREWALL
BETWEEN FLATS 8-9, 11-12
(1-2, 5-6)**
1:50

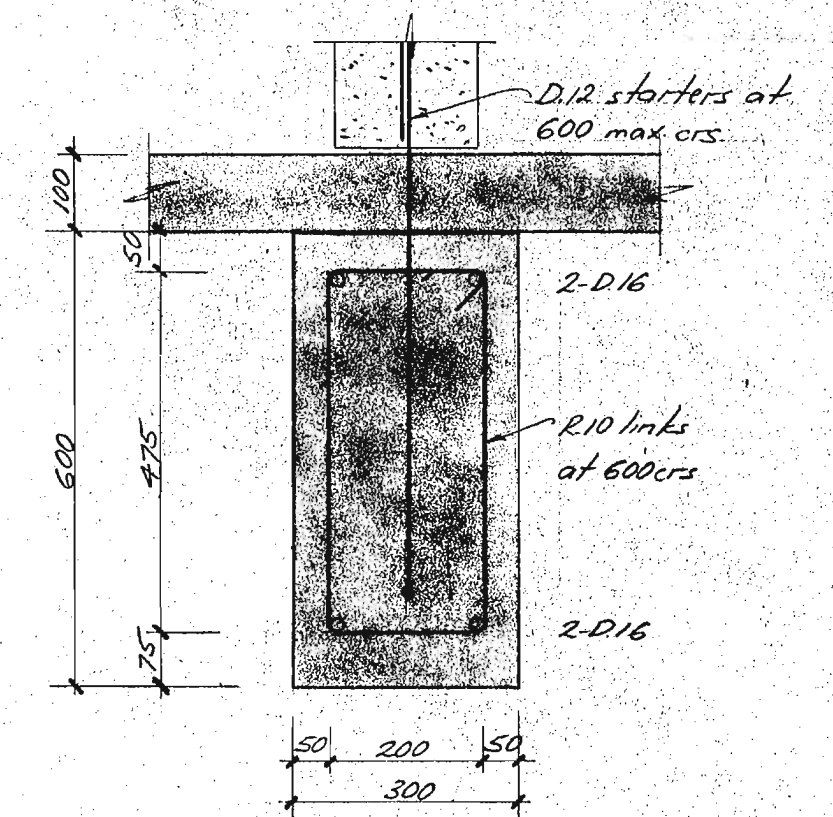
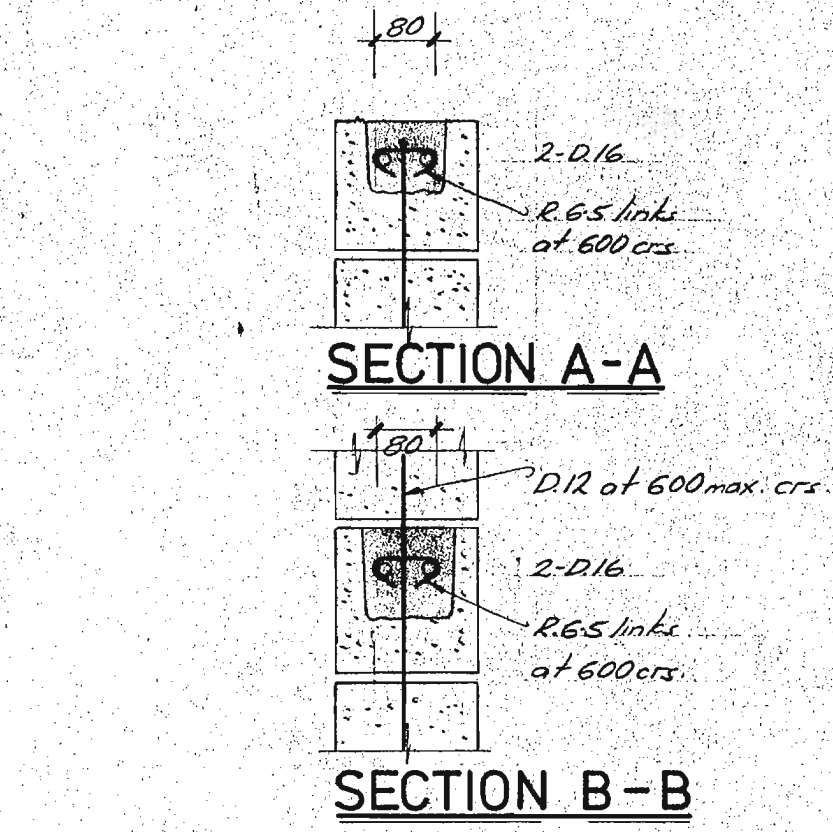

SECTION C-C
1:10

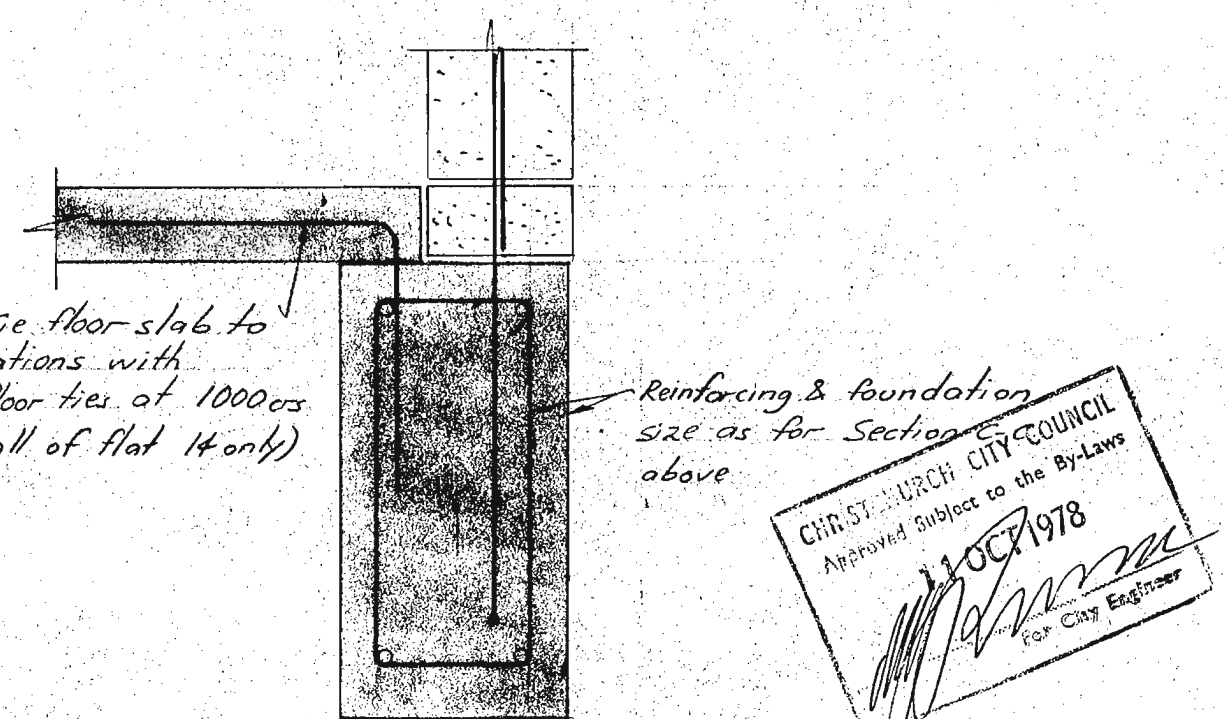

**SECTION C-C
(End wall of flat 14)**
FIREWALLS

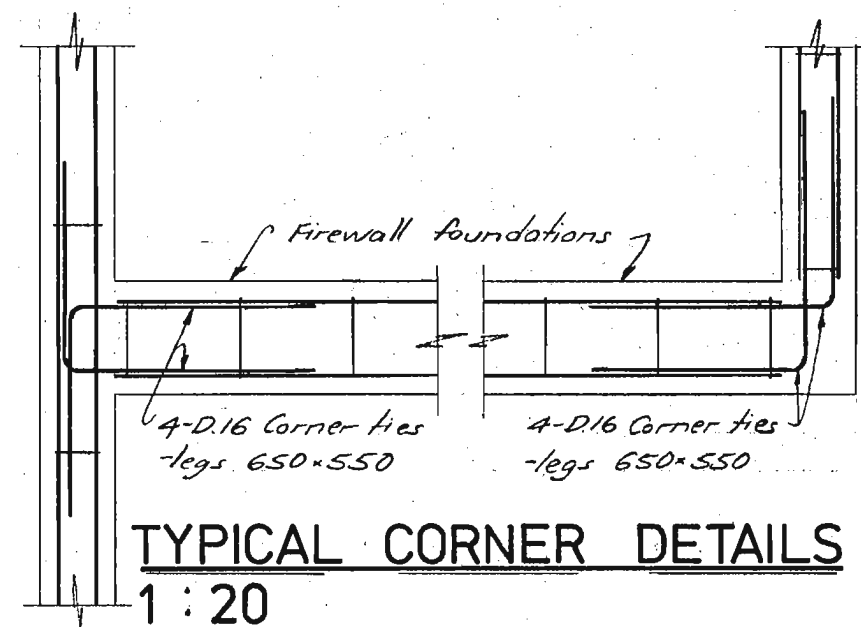

TYPICAL CORNER DETAILS
1:20

NOTES:-
GENERAL
No change or variation is to be made to any structural element without the specific instructions or consent being given in writing by the consulting engineer.
FOUNDATIONS
Foundations must be taken down to solid bearing.
BLOCKWORK
All blockwork shall comply with the relevant clauses of N.Z.S. 1900, Chapter 9.2 - 1964.
Mortar shall be mix N°1 (12.5 MPa) as defined in N.Z.S. 1900, Chapter 9.2.
Provide clean out pockets at floor level to all reinforced cores.
Block filling shall have a minimum 28 day compressive strength of 17.5 MPa.
REINFORCING
All main reinforcing shall be deformed steel to N.Z.S. 3402P Grade 275.
Reinforcing shall be accurately positioned and maintained in the centre of the cavity unless detailed otherwise.
Reinforcing shall be tied to starter bars and at laps Laps shall be a minimum of 40 diameters of the smaller bar.

LIN

2000

151 Stanmore Rd

LINIV.
E.P.M. 14 UNITS
STANMORE RD.

78-2000

RECALL FILE LABEL
F5000013181204

22

78-2000

0007-81
78-2000

Appendix C
CERA Building Evaluation Form

Detailed Engineering Evaluation Summary Data

V1.11

Location

Building Name:

Unit No: Street

Building Address:

Legal Description:

GPS south:

GPS east:

Building Unique Identifier (CCC):

Reviewer:

CPEng No:

Company:

Company project number:

Company phone number:

Date of submission:

Inspection Date:

Revision:

Is there a full report with this summary?

Site

Site slope:

Soil type:

Site Class (to NZS1170.5):

Proximity to waterway (m, if <100m):

Proximity to clifftop (m, if < 100m):

Proximity to cliff base (m,if <100m):

Max retaining height (m):

Soil Profile (if available):

If Ground improvement on site, describe:

Approx site elevation (m):

Building

No. of storeys above ground:

Ground floor split?:

Storeys below ground:

Foundation type:

Building height (m):

Floor footprint area (approx):

Age of Building (years):

Strengthening present?:

Use (ground floor):

Use (upper floors):

Use notes (if required):

Importance level (to NZS1170.5):

single storey = 1

Ground floor elevation (Absolute) (m):

Ground floor elevation above ground (m):

if Foundation type is other, describe:

height from ground to level of uppermost seismic mass (for IEP only) (m):

Date of design:

If so, when (year)?

And what load level (%g)?

Brief strengthening description:

Gravity Structure

Gravity System:

Roof:

Floors:

Beams:

Columns:

Walls:

truss depth, purlin type and cladding

slab thickness (mm)

overall depth x width (mm x mm)

typical dimensions (mm x mm)

Load bearing timber frame with concrete masonry veneer

Building: Current Placard Status:

Along Damage ratio: Describe how damage ratio arrived at:

Describe (summary):

Across Damage ratio: $Damage_Ratio = \frac{(\%NBS(before) - \%NBS(after))}{\%NBS(before)}$

Describe (summary):

Diaphragms Damage?: Describe:

CSWs: Damage?: Describe:

Pounding: Damage?: Describe:

Non-structural: Damage?: Describe:

Recommendations

Level of repair/strengthening required: Describe:

Building Consent required: Describe:

Interim occupancy recommendations: Describe:

Along Assessed %NBS before: ##### %NBS from IEP below If IEP not used, please detail assessment methodology:

Assessed %NBS after:

Across Assessed %NBS before: ##### %NBS from IEP below

Assessed %NBS after:

IEP Use of this method is not mandatory - more detailed analysis may give a different answer, which would take precedence. Do not fill in fields if not using IEP.

Period of design of building (from above): 1976-1992 h_n from above: m

Seismic Zone, if designed between 1965 and 1992:

not required for this age of building

not required for this age of building

	along	across
Period (from above):	0.4	0.4
(%NBS) _{nom} from Fig 3.3:	<input type="text"/>	<input type="text"/>
Note:1 for specifically design public buildings, to the code of the day: pre-1965 = 1.25; 1965-1976, Zone A =1.33; 1965-1976, Zone B = 1.2; all else 1.0		
Note 2: for RC buildings designed between 1976-1984, use 1.2		
Note 3: for buildngs designed prior to 1935 use 0.8, except in Wellington (1.0)		
Final (%NBS)_{nom}:	0.0%	0.0%

2.2 Near Fault Scaling Factor

Near Fault scaling factor, from NZS1170.5, cl 3.1.6:

	along	across
Near Fault scaling factor (1/N(T,D)), Factor A:	#DIV/0!	#DIV/0!

2.3 Hazard Scaling Factor

Hazard factor Z for site from AS1170.5, Table 3.3:

Z₁₉₉₂, from NZS4203:1992

Hazard scaling factor, **Factor B:**

2.4 Return Period Scaling Factor

Building Importance level (from above):
 Return Period Scaling factor from Table 3.1, **Factor C:**

2.5 Ductility Scaling Factor

Assessed ductility (less than max in Table 3.2)
 Ductility scaling factor: =1 from 1976 onwards; or = μ , if pre-1976, from Table 3.3:
 Ductility Scaling Factor, **Factor D:**

2.6 Structural Performance Scaling Factor:

Sp:
 Structural Performance Scaling Factor **Factor E:**

2.7 Baseline %NBS, (NBS%)_b = (%NBS)_{nom} x A x B x C x D x E

%NBS:

Global Critical Structural Weaknesses: (refer to NZSEE IEP Table 3.4)

3.1. Plan Irregularity, factor A:

3.2. Vertical irregularity, Factor B:

3.3. Short columns, Factor C:

3.4. Pounding potential
 Pounding effect D1, from Table to right
 Height Difference effect D2, from Table to right

Therefore, Factor D:

3.5. Site Characteristics

Table for selection of D1	Severe	Significant	Insignificant/none
	Separation 0<sep<.005H		.005<sep<.01H
Alignment of floors within 20% of H	0.7	0.8	1
Alignment of floors not within 20% of H	0.4	0.7	0.8

Table for Selection of D2	Severe	Significant	Insignificant/none
	Separation 0<sep<.005H		.005<sep<.01H
Height difference > 4 storeys	0.4	0.7	1
Height difference 2 to 4 storeys	0.7	0.9	1
Height difference < 2 storeys	1	1	1

3.6. Other factors, Factor F

For ≤ 3 storeys, max value =2.5, otherwise max valule =1.5, no minimum
 Rationale for choice of F factor, if not 1

Detail Critical Structural Weaknesses: (refer to DEE Procedure section 6)

List any: Refer also section 6.3.1 of DEE for discussion of F factor modification for other critical structural weaknesses

3.7. Overall Performance Achievement ratio (PAR)

4.3 PAR x (%NBS)_b:

PAR x Baseline %NBS:

4.4 Percentage New Building Standard (%NBS), (before)

Appendix D
Geotechnical Analysis

CPT ANALYSIS NOTES



Soil Type

Interpretation using chart of Robertson & Campanella (1983). This is a simple but well proven interpretation using cone tip resistance (q_c) and friction ratio (f_R) only. No normalisation for overburden stress is applied. Cone tip resistance measured with the piezocone is corrected with measured pore pressure (u_c).

	sand (and gravel)
	silt-sand
	silt
	clay-silt
	clay
	peat

Liquefaction Screening

The purpose of the screening is to highlight susceptible soils, that is sand and silt-sand in a relatively loose condition. This is not a full liquefaction risk assessment which requires knowledge of the particular earthquake risk at a site and additional analysis. The screening is based on the chart of Shibata and Teparaksa (1988).

	high susceptibility
	medium susceptibility
	low susceptibility

High susceptibility is here defined as requiring a shear stress ratio of 0.2 to cause liquefaction with D_{50} for sands assumed to be 0.25 mm and for silty sands to be 0.05 mm.

Medium susceptibility is here defined as requiring a shear stress ratio of 0.4 to cause liquefaction with D_{50} for sands assumed to be 0.25 mm and for silty sands to be 0.05 mm.

Low susceptibility is all other cases.

Relative Density (D_R)

Based on the method of Baldi et. al. (1986) from data on normally consolidated sand.

Undrained Shear Strength (S_u)

Derived from the bearing capacity equation using $S_u = (q_c - \sigma_{vo})/15$.

DEPTH IN METERS BELOW GROUND LEVEL

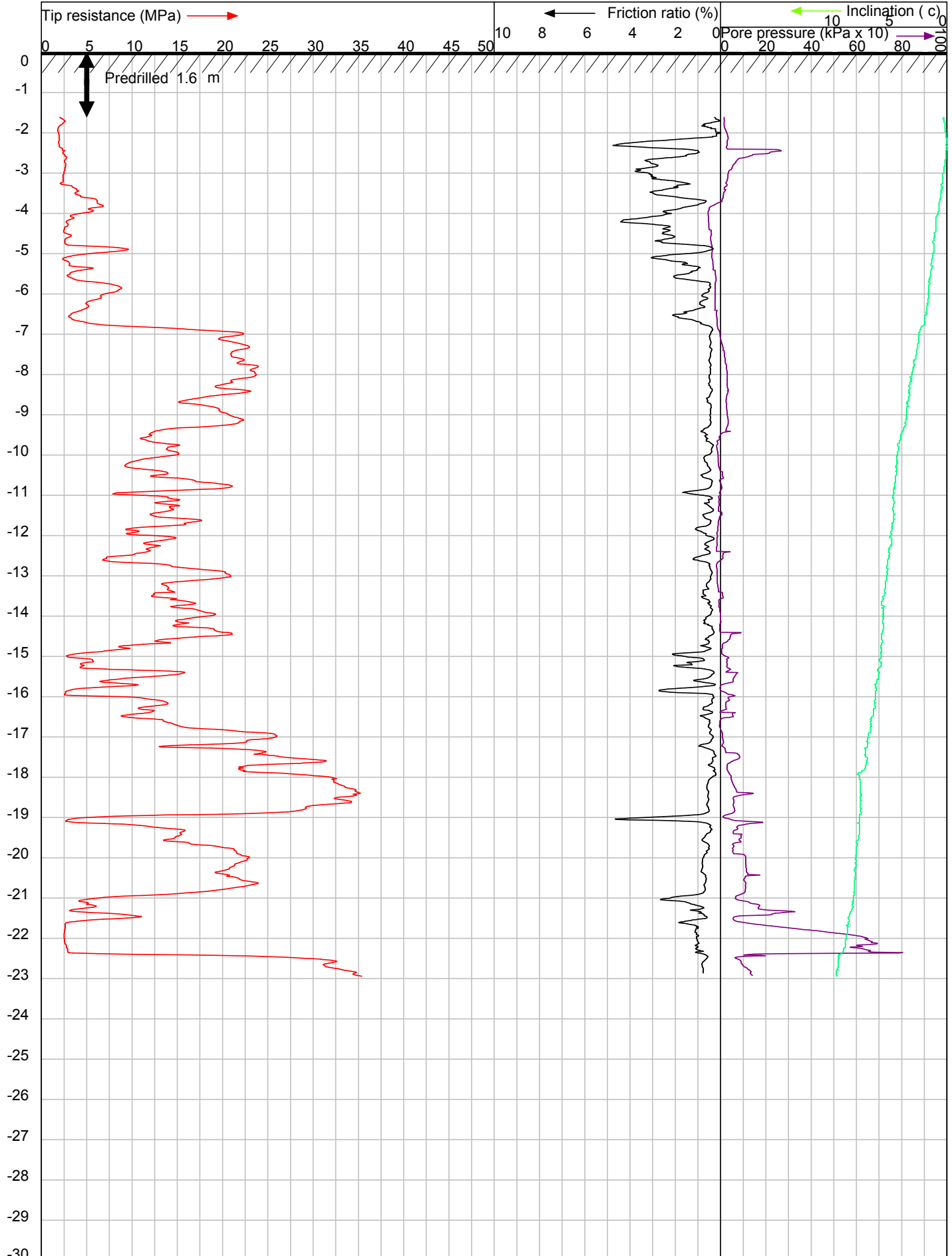

CLIENT : GHD NZ Ltd
LOCATION : 149 Stanmore Road, Christchurch
DATE : 26-6-2012
OPERATOR : S.Cardona
REMARK 1 : CPTu001
REMARK 2 : Effective Refusal

JOB # : 10677
TEST # : 1
CONE TYPE/SERIAL # : I-CFYXP20-10/ 071017T

McMILLAN
DRILLING SERVICES
120 High St Southbridge CANTERBURY NZ
Ph +64 3 324 2571 Fax +64 3 324 2431
www.drilling.co.nz

PIEZOCONE PENETROMETER TEST (CPTU) INTERPRETIVE REPORT

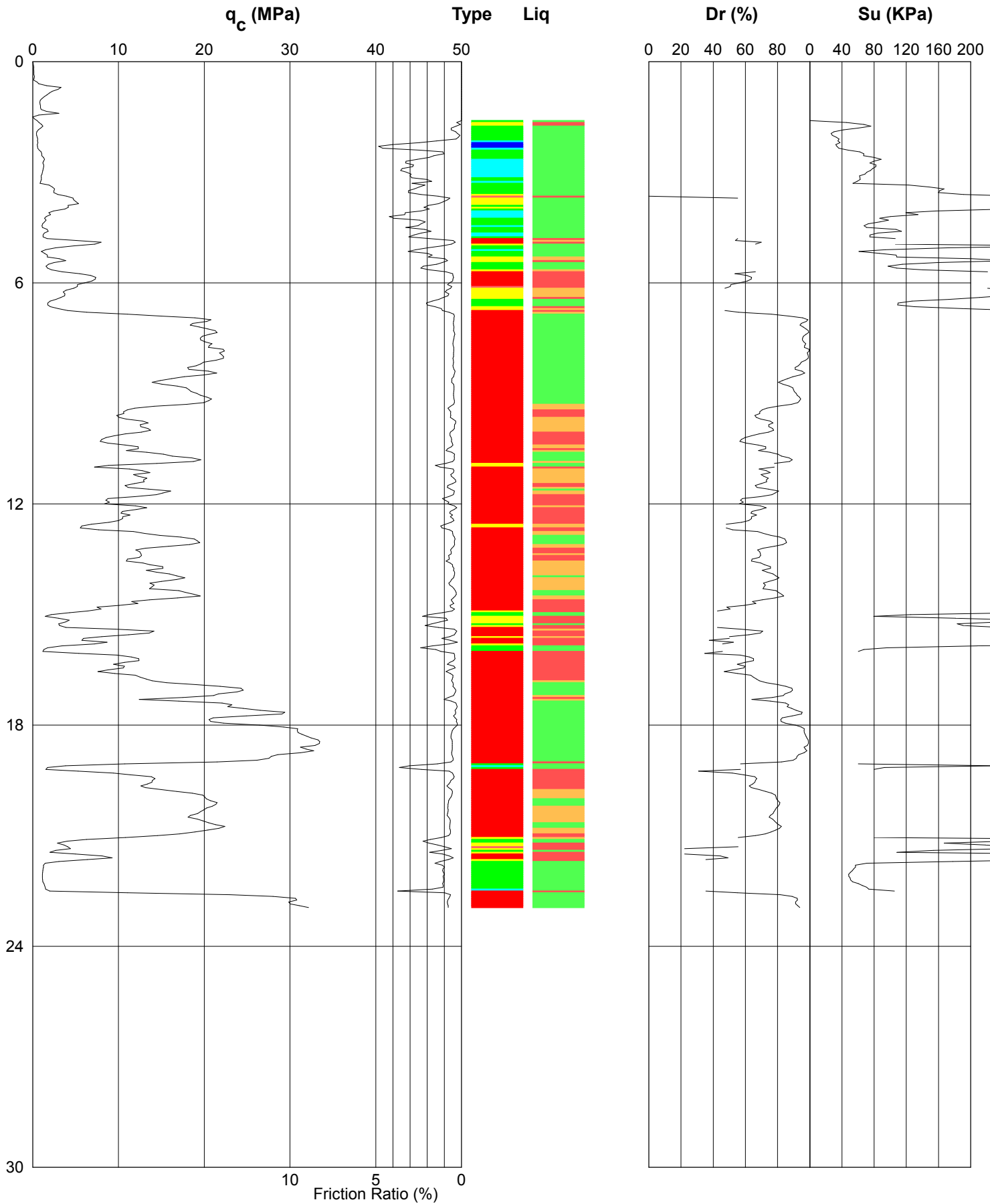

Job No: 10677

CPT No: CPTu001

Project: GHD NZ Ltd

Location: 149 Stanmore Road, Christchurch

Date: 26-6-2012

Operator: S.Cardona

Remark: Effective Refusal

DEPTH IN METERS BELOW GROUND LEVEL

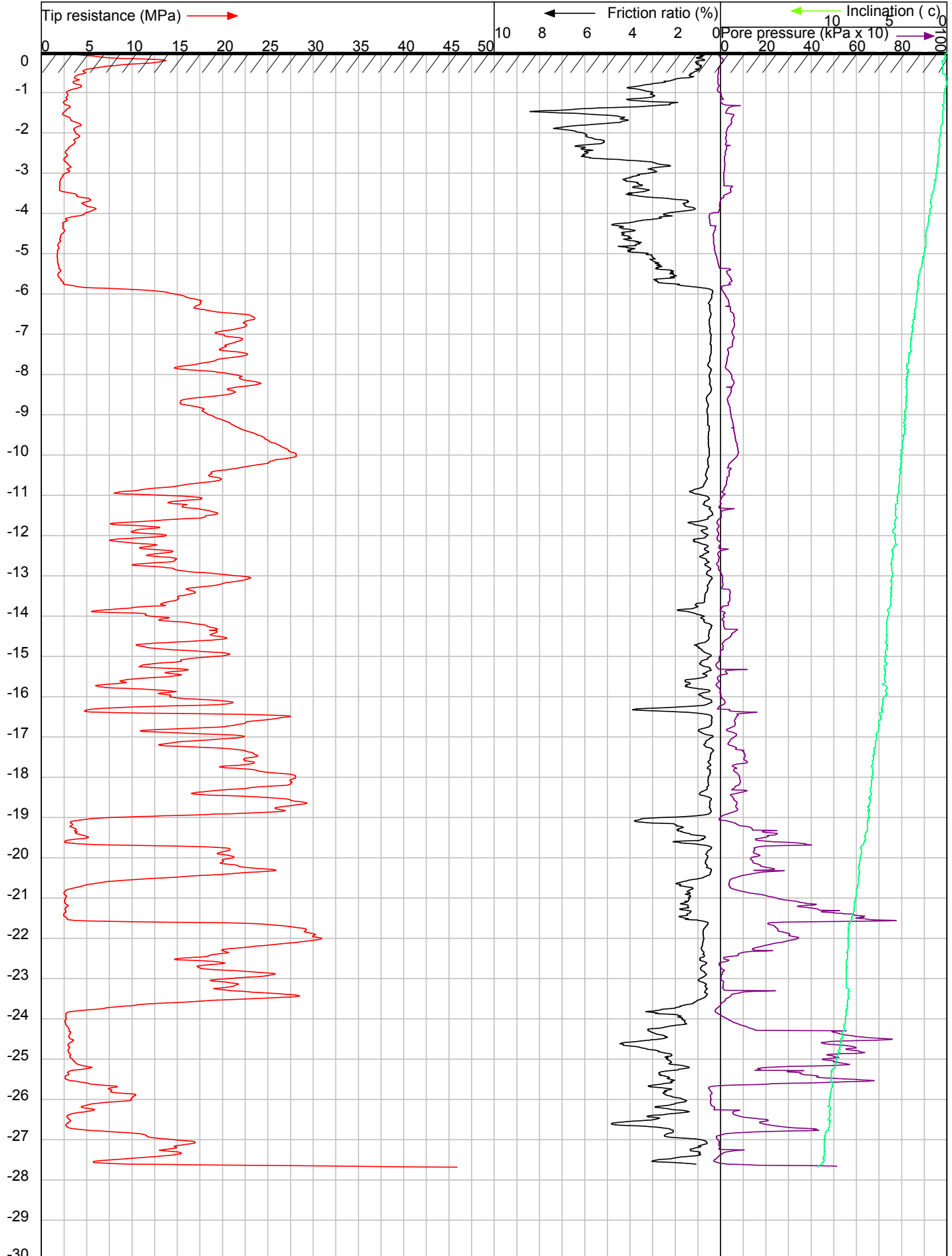

CLIENT : GHD NZ Ltd
LOCATION : 149 Stanmore Road, Christchurch
DATE : 26-6-2012
OPERATOR : S.Cardona
REMARK 1 : CPTu002
REMARK 2 : Effective Refusal

JOB # : 10677
TEST # : 2
CONE TYPE/SERIAL # : I-CFYXP20-10/ 071017T

McMILLAN
DRILLING SERVICES
120 High St Southbridge CANTERBURY NZ
Ph +64 3 324 2571 Fax +64 3 324 2431
www.drilling.co.nz

PIEZOCONE PENETROMETER TEST (CPTU) INTERPRETIVE REPORT

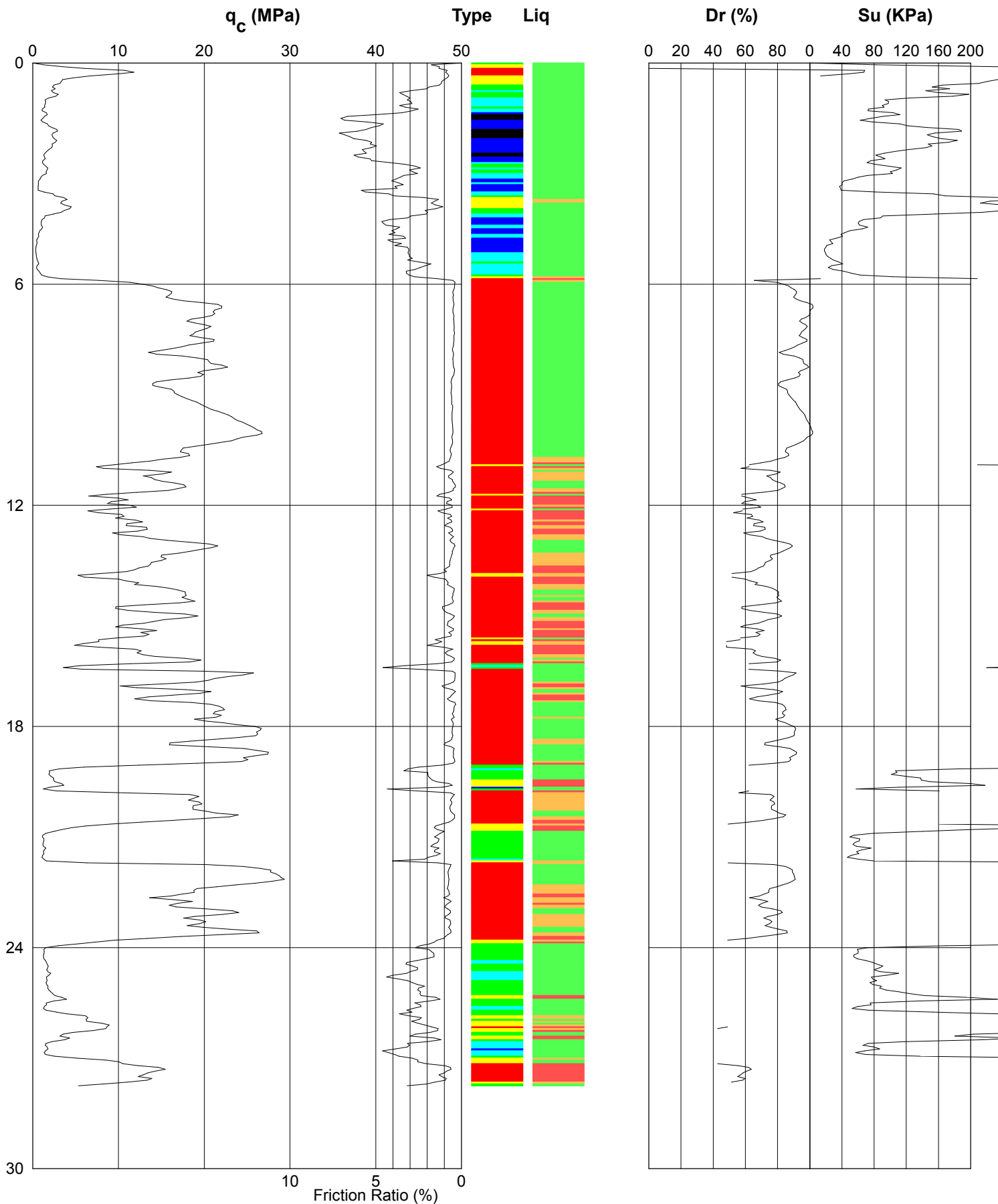

Job No: 10677

CPT No: CPTu002

Project: GHD NZ Ltd

Location: 149 Stanmore Road, Christchurch

Date: 26-6-2012

Operator: S.Cardona

Remark: Effective Refusal

CIVIL CONSTRUCTION OVERVIEW

- 5 x Piling Rigs (20 to 80 tonne);
- 4 x Tieback/Micro-Piling Rigs (0.5 to 20 tonne);
- Sheet Piling & Injection Grouting;
- Dewatering;
- 26 x Drilling Rigs Company wide.

A NEW ZEALAND FIRST METHOD – INTRODUCED TO THE MARKET BY MCMILLAN’S:

Provisionally Patented Vibration Free Stone Column Method:



- Can be used next to sensitive buildings;
- No mess (dry);
- Cost effective (minimal setup times);
- Further savings possible for building construction – i.e. ground beams, deep rafts, pile starters, boxing to piles;
- No corrosion issues, all natural materials;
- Reliance on individual piles, and the risk of differential settlement is reduced.

Fully Instrumented Continuous Flight Auger / Displacement Auger Piling:



- Cost effective;
- Sizes 350mm to 900mm and 19m depth;
- Fast (150m of 600mm diameter reinforced concrete pile can be installed per day);
- Lateral load capacity of RC piles exceed some other piling methods;
- Quiet & vibration free;
- Fully reinforced concrete piles, with no corrosion issues.

MCMILLAN’S ALSO OFFER THE FOLLOWING SERVICES:

- Screw Piles;
- Conventional Bored Concrete Piles;
- Mini & Micro Piles;
- Retaining Walls;
- Sheet Piling;
- Anchors & Tiebacks.

Please contact us to find out more information or visit our website www.drilling.co.nz

MCMILLAN
DRILLING SERVICES

SOIL LIQUEFACTION SUSCEPTIBILITY ASSESSMENT



LOCATION : CPT 1
 PROJECT : Haast Courts - 149 Stanmore Road
 JOB NO : 51 30596 41
 TEST DATE : 28 Jun 2012
 SHEET : 1
 CALCULATED : HNN
 CHECKED BY :
 DATE : 4 Jul 2012

PGA (a_{max}): 0.35 g
 EQ Magnitude: 7.5
 Groundwater Level (m bgl): 1.0
 Atmospheric Pressure (kPa): 101
 Bore depth (m): 23.07
 Test data step (m): 0.01
 Total Estimated Settlement (mm) **267**

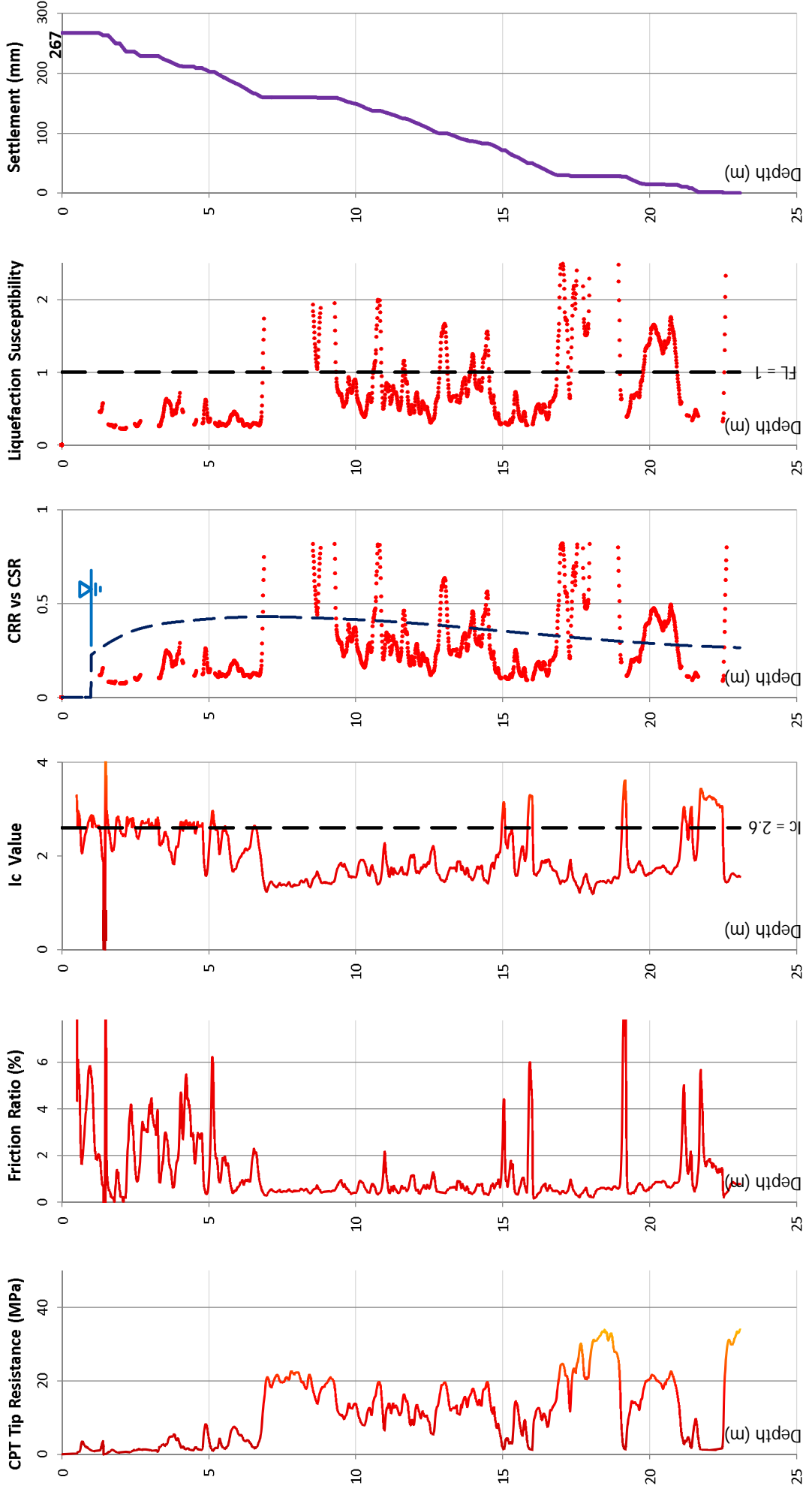

SOIL LIQUEFACTION SUSCEPTIBILITY ASSESSMENT



LOCATION : CPT 2
 PROJECT : Haast Courts - 149 Stanmore Road
 JOB NO : 51 30596 41
 TEST DATE : 28 Jun 2012
 SHEET : 2
 CALCULATED : HNN
 CHECKED BY :
 DATE : 4 Jul 2012

PGA (a_{max}): 0.35 g
 Groundwater Level (m bgl): 1.0
 EQ Magnitude: 7.5
 Atmospheric Pressure (kPa): 101
 Bore depth (m): 27.89
 Test data step (m): 0.01
 Total Estimated Settlement (mm): **157**

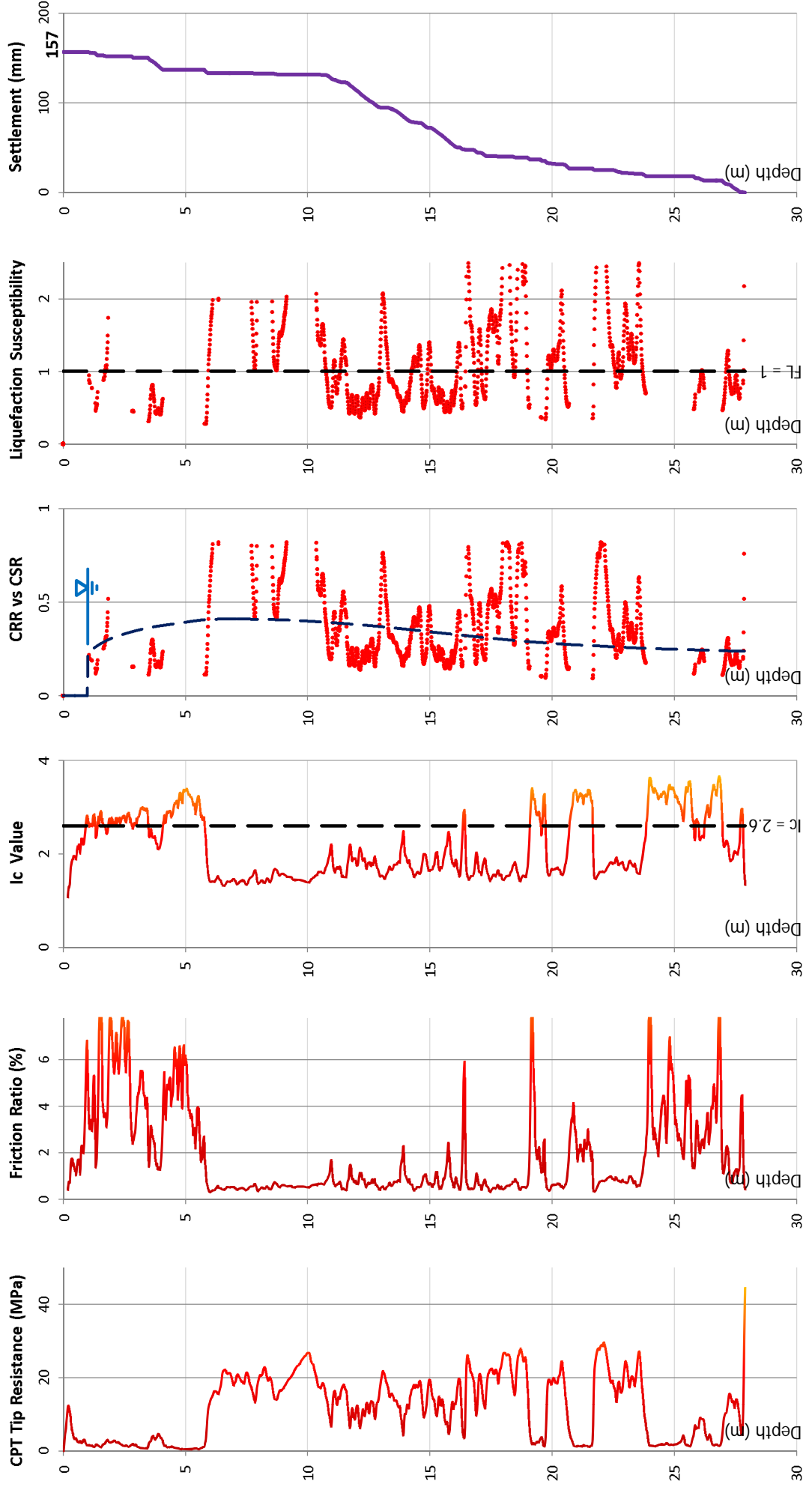



GHD

Level 4, Spicer Building
148 Victoria Street, Christchurch 8013
T: 64 3 378 0900 F: 64 3 377 8575 E: chcmail@ghd.com

© GHD Limited 2012

This document is and shall remain the property of GHD Limited. The document may only be used for the purpose for which it was commissioned and in accordance with the Terms of Engagement for the commission. Unauthorised use of this document in any form whatsoever is prohibited.

Document Status

Rev No.	Author	Reviewer		Approved for Issue		
		Name	Signature	Name	Signature	Date
Draft	Kevan O Brien	Peter O Brien		Derek Chinn		31/10/12